

AERO-MOTIVE COMPANY



A Woodhead Industries, Inc. Subsidiary

IMPORTANT SAFETY INSTRUCTIONS

Please read this manual carefully and follow its instructions. Improper use or failure to follow these instructions could result in serious injury, death or property damage. Operators should be instructed in the safe and proper use and maintenance of this product. Keep this manual for future reference.

The following safety precautions call attention to potentially dangerous conditions.



DANGER: Immediate hazards which **WILL** result in severe personal injury or death.



WARNING: Hazards or unsafe practices which **COULD** result in severe personal injury or death.



CAUTION: Hazards or unsafe practices which **MAY** result in *minor* personal injury or product or property damage.

NOTE: Instruct operators in the safe, proper use and maintenance. Keep this manual for future reference.

INSTALLATION



WARNING: Failure to read, understand or follow these instructions could lead to hazards or unsafe practices **COULD** result in severe personal injury or death.



CAUTION: Instruct operators in the safe, proper use and maintenance of this product. Hazards or unsafe practices **MAY** result in *minor* personal injury or product or property damage.

SWINGING MOUNTING

Hang torque reel in desired location by clevis provided at top. Torque reel should be suspended directly over work area (see illustration), using an eyebolt or similar device with a break strength exceeding 6 times the combined weight of torque reel and load it is supporting. Torque reel should be mounted in such a manner as to minimize cable contact with cable guide. For proper alignment, utilize three (3) mounting holes at top of torque reel. If shackle is removed to make connections, be sure nut and cotter pin are properly replaced on shackle pin.

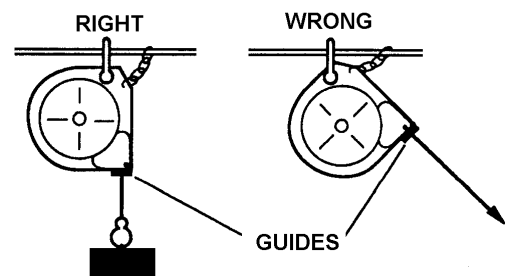

RIDGID MOUNT

Install torque reel in desired location using rigid mount housing. Use housing as a template to drill mounting holes. Mount reel in line with cable pay out to minimize rubbing of cable against cable guide.

SECONDARY SUPPORT CHAIN



DANGER: A secondary safety cable or chain is to be attached to all Torque Reels mounted overhead to prevent reel from falling. Immediate hazards **WILL** result in severe personal injury or death.

A hole has been provided at side of the housing to permit installation of a secondary support chain. All reels mounted over head must have a secondary support chain to protect personnel in case of structure or mounting component failure. Attach one end of secondary support chain or cable to secondary support point on reel. Attach other end of secondary support chain or cable to a support component other than

that which supports the torque reel. Chain or cable should be as short as possible allowing reel to drop no more than 6 to 12 inches if the primary connection is released. (See illustration above). A secondary support is offered as an accessory item.

OPERATION

TOOL ATTACHMENT

WARNING: Never pull cable to device to be retracted. Always lift object to hook. If the hook is accidentally released when it is extended, it will snap back. Hazards or unsafe practices **COULD** result in severe personal injury or death.

If, after installation, it is determined the cable overhang is not sufficient; an overhang extension cable can be used to extend overhang without reducing the active travel. This is available as an optional item. Torque reel is furnished with a tool clip. Attach tool complete with hose or cable and fittings. To adjust length of overhang, remove all tension, then pull down and position hook at desired height. Loosen cable stop, then slide cable stop upward to roller guide and tighten. Move cable stop upward and lengthen overhang of cable to reduce active travel distance. For every foot more of overhang adjusted on torque reel cable, there is an equal reduction in cable travel.

SPRING TENSION ADJUSTMENT

WARNING: Attach full load including all attachments before adjusting tension. Hazards or unsafe practices **COULD** result in severe personal injury or death.

WARNING: When releasing tension, always do so slowly, and with wrench held firmly on shaft flats. Gloves should be worn when using tension release lever. Hazards or unsafe practices **COULD** result in severe personal injury or death.

Tool including all attachments and connections must be in place before adjusting spring tension.

- If load exceeds spring tension, tool will drop, and tension must be increased.
- If tool is fully retracted but spring tension, seems excessive (rapid retraction), decrease tension.

Tension should always be enough to retract tool and to keep cable stop against guide.

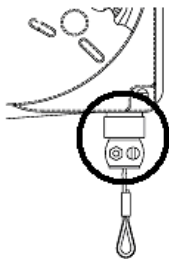

To Increase Tension

Engage a wrench on flats on mainspring shaft and turn in “+” direction (as shown in diagram).

To Decrease Tension

Engage a wrench on flats on mainspring shaft. As tension release lever on opposite side of torque reel is gently pushed, shaft will unwind. Control unwinding with firmly held wrench.

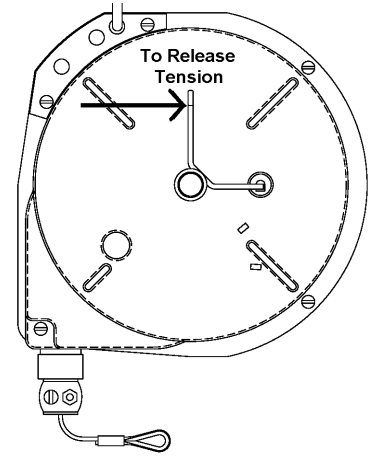
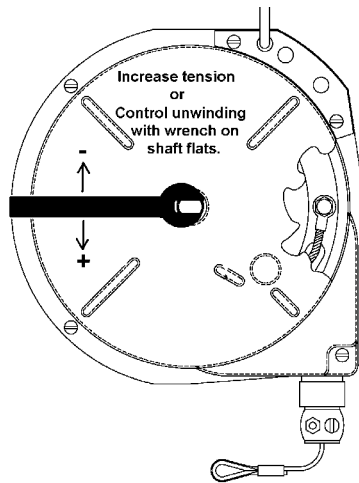

After adjusting tension, pull cable to fullest extension to ensure full cable travel. If cable does not reach full extension, some tension must be released. If proper tension and extension cannot be achieved, another unit may be required. Please consult factory.

RATCHET LOCK

The ratchet lock works in two positions in one complete rotation. Pull cable to desired location and let cable retract slightly until lock engages. To release lock, pull cable out about 6". For constant tension,

ratchet lock may be disengaged. Turn lock release knob counterclockwise while pulling cable in and out slightly to engage lock release lever.

CABLE STOP ADJUSTMENT

Cable stop can be moved up along cable to attain most desirable working height.

NOTE: Moving the cable stop will reduce the active travel distance. If additional cable extension is required, extension cable assemblies (Kit E) are offered as an accessory.

SERVICE

MAIN SPRING REPLACEMENT

WARNING: Remove all tension before removing mainspring. Hazards or unsafe practices **COULD** result in severe personal injury or death.

WARNING: Spring is dangerous. Always wear gloves. Before removing broken spring, weld coils together at four (4) locations or wrap securely with wire. Hazards or unsafe practices **COULD** result in severe personal injury or death.

Remove **All** tension from main spring (See Spring Tension Adjustment). Remove cotter pin and then clevis. Next remove the retaining ring and the three (3) screws, also plates and screws. Remove housing. Remove drum-cover nuts and cover. Carefully remove mainspring from drum. Hub may come off shaft with spring.

If so, replace hub into new spring while making sure hub engages spring coils. Replace spring in drum while making sure the spring engages in the lip on drum. To reassemble, reverse the above procedure. Be sure the hub engages the pin on the main shaft when reassembling.

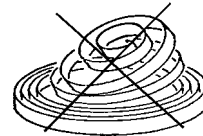

CABLE REPLACEMENT

Whenever a cable shows signs of deterioration, it should be replaced with a new cable. Remove **All** tension from main spring (See Spring Tension Adjustment). Remove clevis by removing the cotter pin. Next remove the retaining ring and the three (3) screws, also plates and screws. Remove housing. Remove nut and cable. Replace with new cable while threading it through guide first when reassembling.

RATCHET LOCK REPLACEMENT

Remove **All** tension from main spring (See Spring Tension Adjustment). Remove clevis by removing the cotter pin. Next remove the retaining ring and the three (3) screws, also plates and screws. Remove retaining ring, washer, and spring lock, and retaining ring. The housing can now be removed. Remove retaining ring and unclip spring, then remove ratchet lock. To reassemble, reverse the above procedure.

PARTS REPLACEMENT

CAUTION: Always remove all spring tension (see "Spring Tension Adjustment") before attempting to disassemble internal parts. Always remove torque reel from service. Hazards or unsafe practices **MAY** result in *minor* personal injury or product or property damage.

NOTE: When ordering replacement parts, always include torque reel model number and serial number.

All parts are replaceable in the field without special tools.

LUBRICATION

All bearings, springs, etc. are permanently lubricated at factory and should require no further lubrication.

MAINTENANCE & INSPECTION

Due to the design, this reel will require little maintenance other than a periodic check of the cable, afety chain, and hanger for wear. All worn parts or cable should be removed from service and/or replaced at once.

REPLACEMENT PARTS

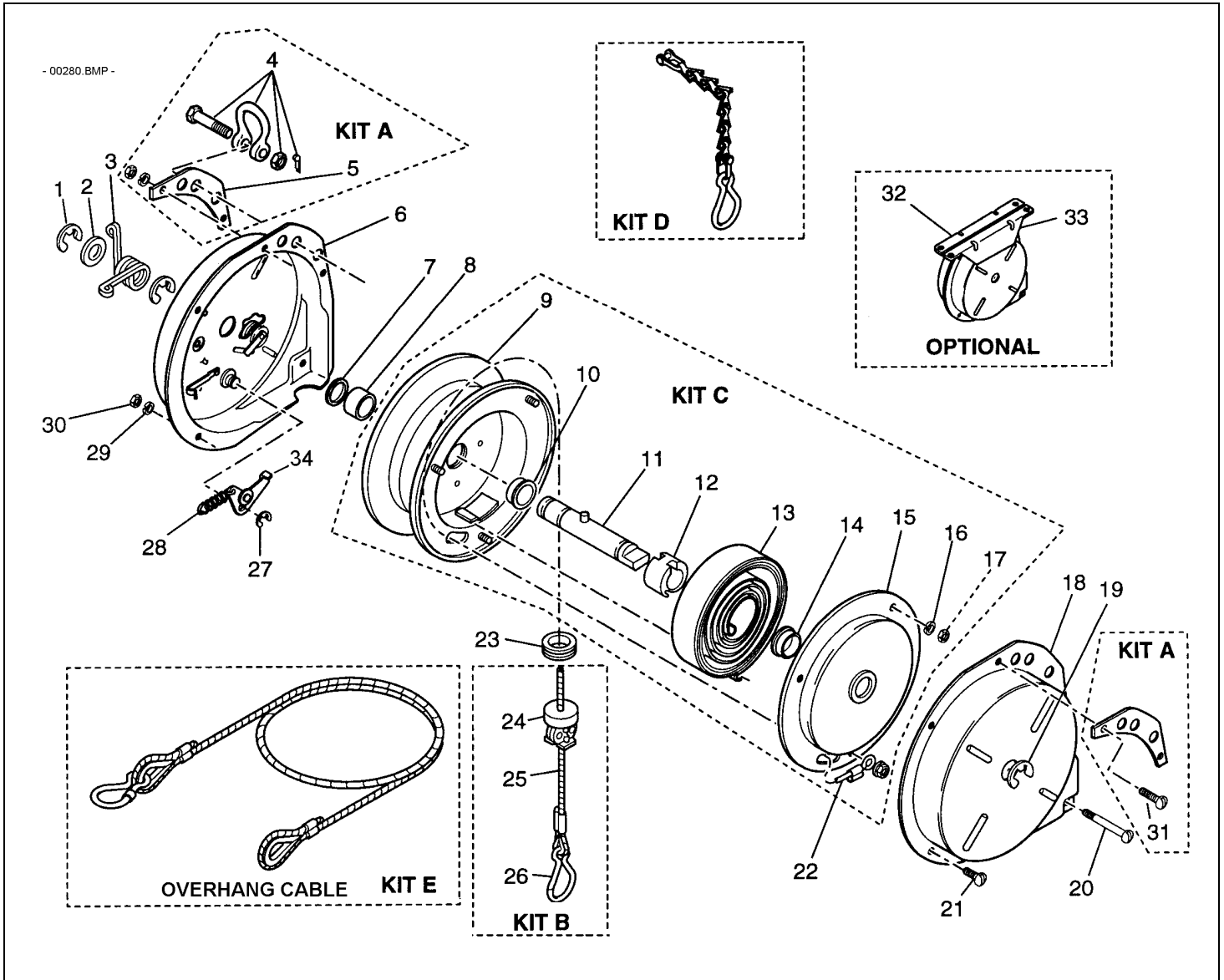

Ref. No.	Part Number	Qty.	Description
1	00580P0045	2	Retaining Ring (.625)
2	0981300000	1	Washer
3 *	0961600000	1	Spring tension Lock
4	01240P0010	1	Clevis Assembly (included in Kit A)
5	M62710002	2	Hanger-mounting plate (included in Kit A)
6	0988600000	1	Housing Assembly
7	1409900000	AR	Spacer (used for shim only)
8	0961100000	1	Spacer
9	0967100000	1	Cable drum Assembly (included in Kit C)
10	1361000002	1	Bearing, Main shaft (included in Kit C)
11	0967300000	1	Main shaft (included in Kit C)
12	1405800002	1	Spring hub (included in Kit C)
13 *	0961800239	1	Spring (included in Kit C) 1515T & 1515TR
	0961800030	1	Spring for model 0515T
	0961800203	1	Spring for model 1015T
14	1361000001	1	Bearing, Main shaft (included in Kit C)

15	0967100000	1	Cover (included in Kit C)
16	00103P0035	2	Washer, Lock (#8, internal tooth)(included in Kit C)
17	00151P0085	2	Nut (#8 - 32)(included in Kit C)
18	0962100000	1	Housing
19	00580P0035	1	Retaining Ring
20	00002P0114	1	Screw (#8 - 32 x 1 3/4)
21	00002P0101	2	Screw (#8 - 32 x 5/16)
22	00160P0078	1	Locknut (#8 - 32)(included in Kit C)
23	1361300000	1	Cable Guide
24	0983300000	1	Adjustable Cable Stop (included in Kit B)
25 *	0963900015	1	Cable (15 ft.)(included in Kit B)
26	01146P0015	1	Hook (included in Kit B)
27	00058P0030	1	Retaining Ring (.375)
28	H05040010	1	Springs kit
29	00103P0035	5	Washer, Lock (#8 internal tooth)
30	00151P0085	5	Nut (#8 - 32)
31	00002P0105	2	Screw (#8 - 32 x 5/8)(included in Kit A)
32	0970100000	A/R	Housing (rigid mount)
33	0973100000	A/R	Housing (rigid mount)
34	0962200000	1	Ratchet Lever

OPTIONAL KITS

Kit A	H16510007		Clevis Kit (includes items 4, 5, 31)
Kit B	0967800015		Cable Assembly (includes items 24, 25, 26)(kit B)
Kit C	0988700239		Mainspring, Drum, & Shaft Assy for 1515T & 1515TR (items 9-17, 22)
Kit D	4963800000	A/R	Safety Chain
Kit E	4965000001		Cable Overhang (3 ft.)

* Recommended Spare Parts

Aero-Motive Company

W A Woodhead Industries Inc. Subsidiary
 PO Box 2678
 Kalamazoo, MI 49003-2678
 USA
 (269) 337 7700 / (800) 999 8559
 FAX: (800) 333 6119
 www.aeromotive.com
 techhelp@aeromotive.com

Woodhead Connectivity LTD.

W A Woodhead Industries Inc. Subsidiary
 Factory No. 9
 Rassau Industrial Estate
 Ebbw Vale Gwent NP23 5SD
 United Kingdom
 44-1495-356300
 FAX: 44-1495-356301
 sales@wdhd.co.uk

Woodhead Asia PTE LTD.

W A Woodhead Industries Inc. Subsidiary
 No. 4 Toh Tuck Link
 Level 3 Mezzanine
 Markono Logistics Bldg.
 Singapore 596226
 65-6-261-6533
 FAX: 65-6-261-3588
sales@wasia.com.sg

Woodhead Canada LTD.

W A Woodhead Industries Inc. Subsidiary
 1090 Brevik Place
 Mississauga Ontario
 L4W 3Y5 Canada
 (905) 624-1079
 FAX: (905) 624-9151
www.woodhead.ca