

ALL DIMENSIONS ARE FOR REFERENCE ONLY.

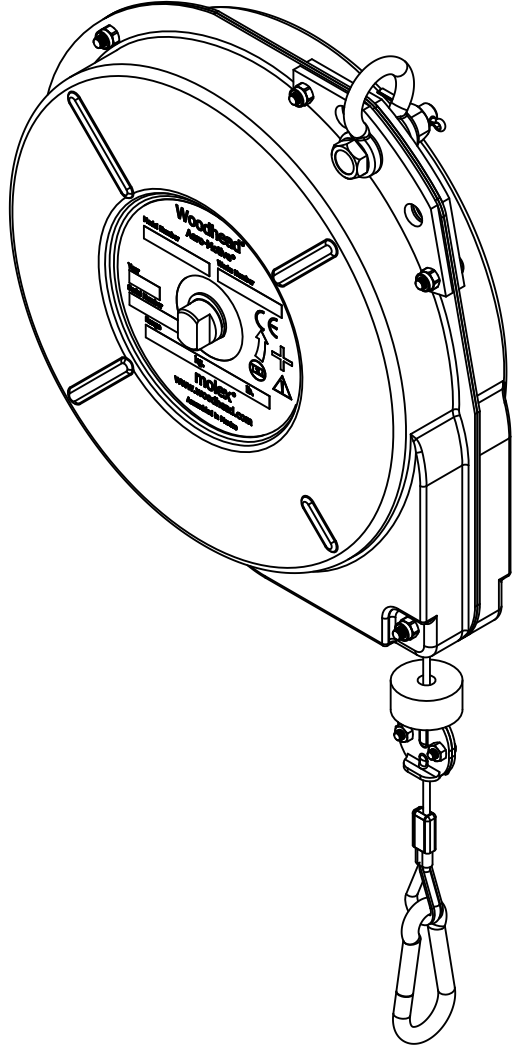
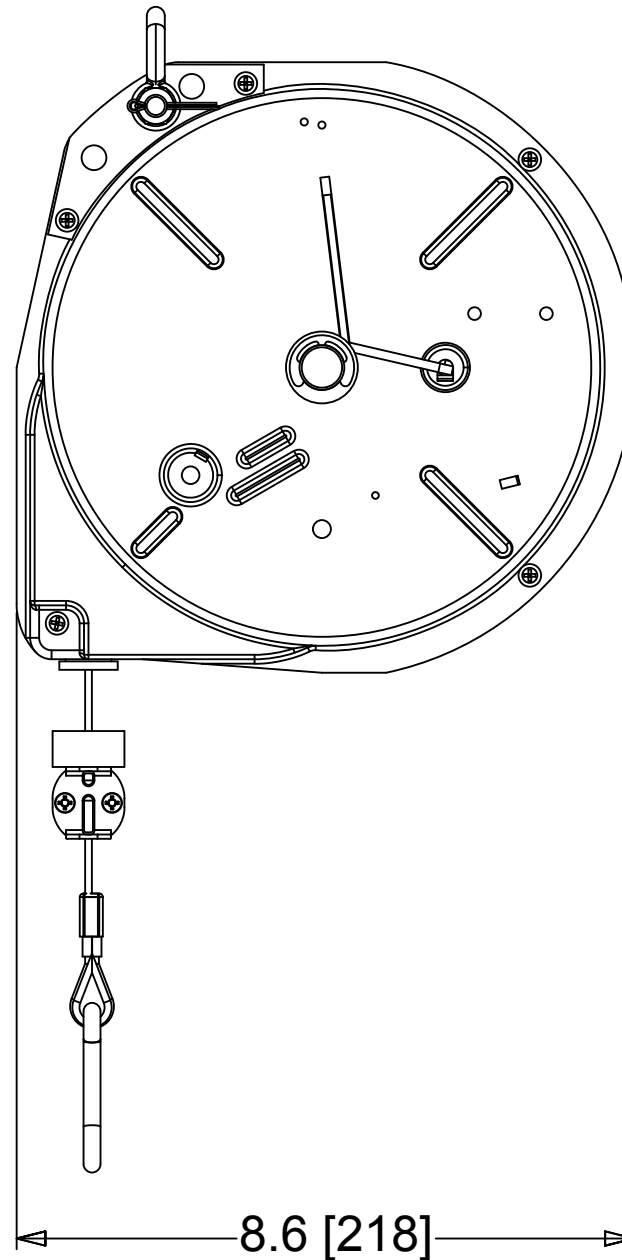
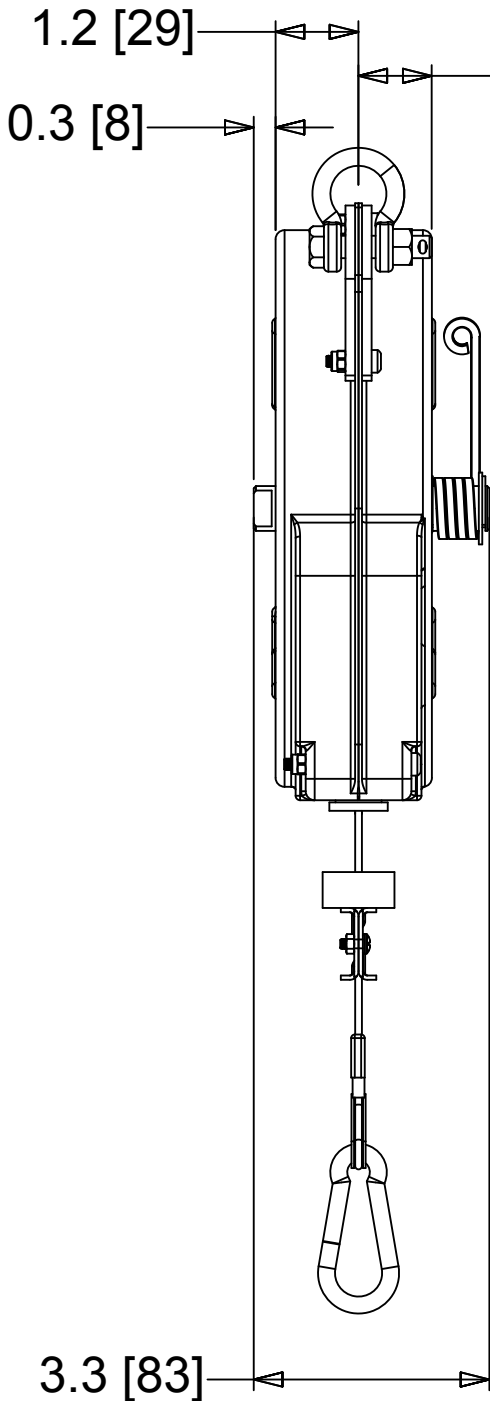
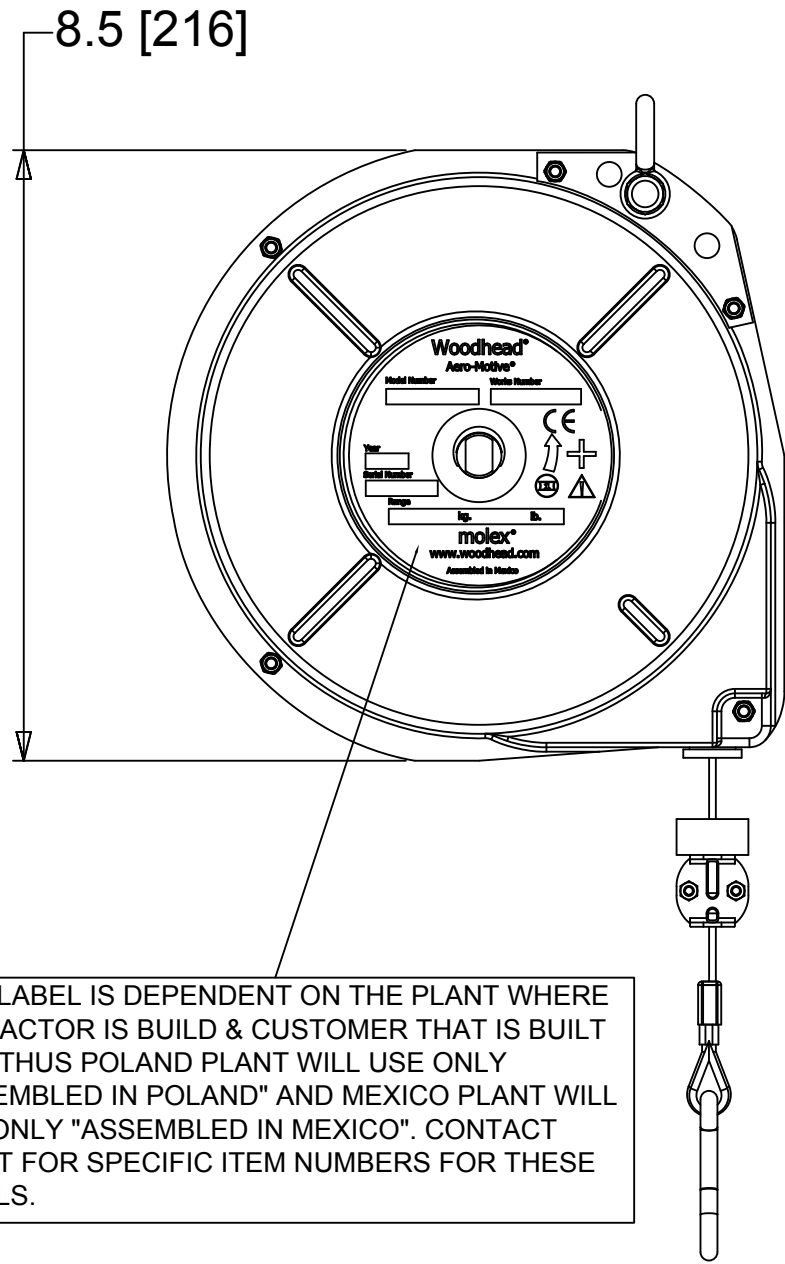

THIS LABEL IS DEPENDENT ON THE PLANT WHERE RETRACTOR IS BUILD & CUSTOMER THAT IS BUILT FOR. THUS POLAND PLANT WILL USE ONLY "ASSEMBLED IN POLAND" AND MEXICO PLANT WILL USE ONLY "ASSEMBLED IN MEXICO". CONTACT PLANT FOR SPECIFIC ITEM NUMBERS FOR THESE LABELS.

- NOTES:
1. RETRACTORS ARE 100% INSPECTED & PRE-TENSIONED AT FACTORY.
  2. STEEL HOUSINGS HAVE A POWDER COATED FINISH TO MEET HARSH INDUSTRIAL ENVIRONMENTS.
  3. ALWAYS READ INSTRUCTIONS MANUAL BEFORE USING RETRACTORS.
  4. RETRACTORS ARE NOT TO BE USED AS BALANCERS THEIR MAIN PURPOSE BEING TO RETRACT A LOAD AND NOT TO BALANCE ONE.
  5. STANDARD RETRACTORS DO NOT COME EQUIPPED WITH A SAFETY CHAIN. IF APPLICATION REQUIRES A SAFETY CHAIN ADD "SC" SUFFIX TO STANDARD PART NUMBER. EXAMPLE 15FSC.
  6. WHEN MOUNTING RETRACTOR, ALWAYS MAKE SURE THAT SAFETY PIN WHICH COMES WITH SHACKLE IS INSTALLED & SECURED.

RELEASE TO SALES EC NO: --- 9/17/09 DRWN: RHOTCA CHKD: DT 2009/09/17 APPR: ---	QUALITY SYMBOLS ▽=0 ◁=0	GENERAL TOLERANCES (UNLESS SPECIFIED)		DIMENSION STYLE IN/MM		SCALE NTS	DESIGN UNITS INCH	THIRD ANGLE PROJECTION		
		4 PLACES	mm	INCH	DRAWN BY	DATE	TITLE 10F/15F/22F SERIES OF RETRACTORS			
		3 PLACES	±NA	±---	RH	2009/09/17				
		2 PLACES	±NA	±NA	CHECKED BY	DATE	MOLEX INCORPORATED			
1 PLACE	±NA	±NA	DT	2009/09/17						
		ANGULAR ±1°		APPROVED BY	DATE	DOCUMENT NO. SD-130175-002		SHEET NO. 1 OF 2		
DRAFT WHERE APPLICABLE MUST REMAIN WITHIN DIMENSIONS		SEE TABLE		THIS DRAWING CONTAINS INFORMATION THAT IS PROPRIETARY TO MOLEX INCORPORATED AND SHOULD NOT BE USED WITHOUT WRITTEN PERMISSION						

RETRACTOR MODEL:		ITEM #1:	ITEM #2:	ITEM #3:	ITEM 18 SAFETY CHAIN USAGE IN ASSEMBY:		RETRACTOR OUTER COLOR
MATERIAL NUMBER	ENGINEERING NUMBER	MATERIAL NUMBER	MATERIAL NUMBER	MATERIAL NUMBER	MATERIAL NUMBER	ENGINEERING NUMBER	
1301750001	10F	1301790115	1301790123	1301790124	N/A	N/A	BLUE
1301790006	15F	1301790115	1301790123	1301790125	N/A	N/A	BLUE
1301750011	22F	1301790115	1301790123	1301790125	N/A	N/A	BLUE
1301750005	10FSC	1301790115	1301790123	1301790124	1301790328	SSPEC	BLUE
1301790010	15FSC	1301790115	1301790123	1301790125	1301790328	SSPEC	BLUE
1301750013	22FSC	1301790115	1301790123	1301790125	1301790328	SSPEC	BLUE

LOAD CAPACITY CHART:			
RETRACTOR MODEL:		EACH RETRACT IS 100% TESTED UNDER THIS WEIGHT:	
MATERIAL NUMBER	ENGINEERING NUMBER	IN LBS:	IN KGS:
1301750001	10F	10	4.5
1301750006	15F	15	6.8
1301750011	22F	22	10

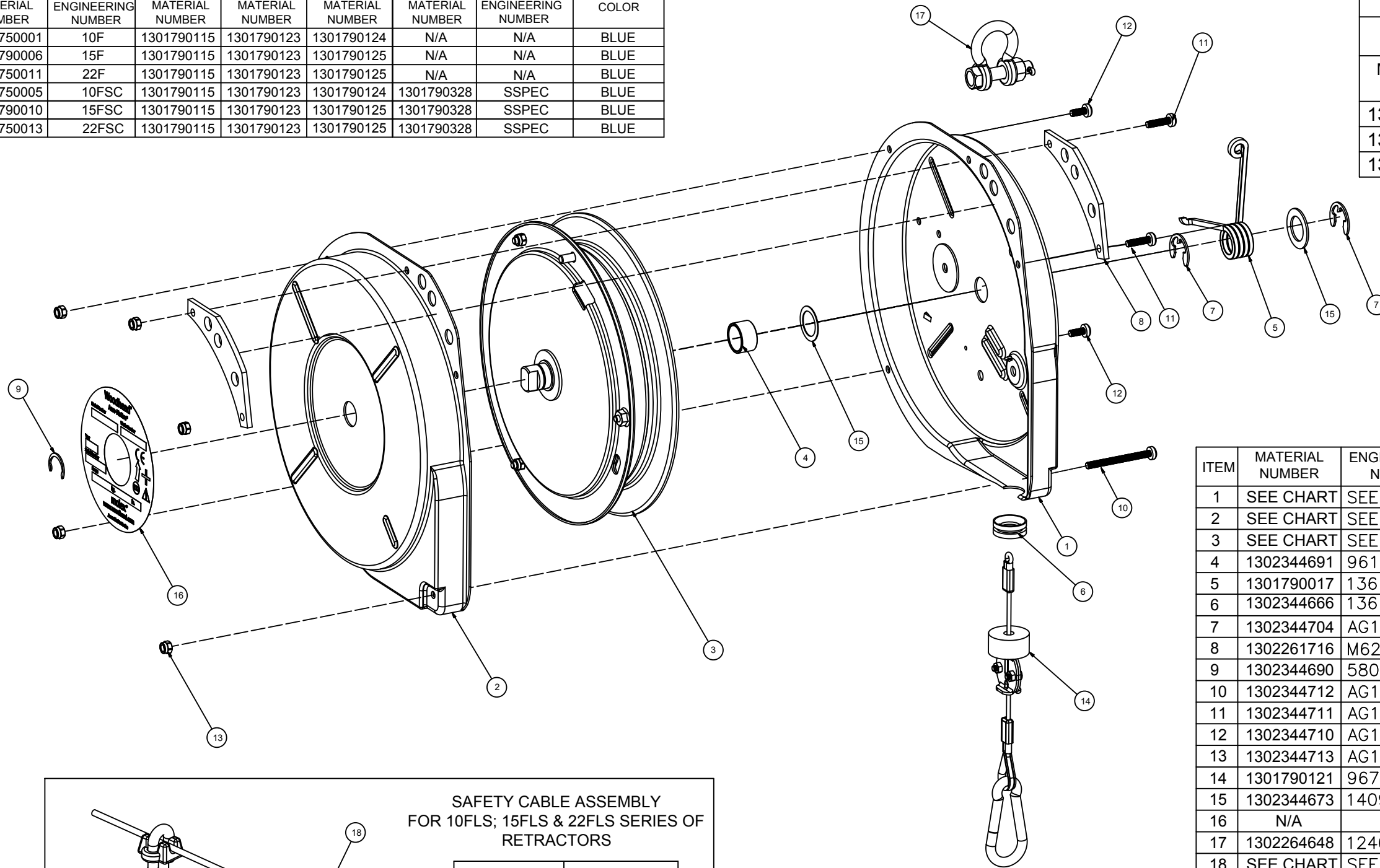

ITEM	MATERIAL NUMBER	ENGINEERING NUMBER	ITEM DESCRIPTION
1	SEE CHART	SEE CHART	10F/15F/22F HSNQ SPRING SIDE - POWDER XXX
2	SEE CHART	SEE CHART	10F/15F/22F HSNQ PLAIN SIDE - POWDER XXX
3	SEE CHART	SEE CHART	10F/15F/22F - ASSY SPRING & CABLE DRUM
4	1302344691	9611-1	MAIN SHAFT SPACER FOR 10F/15F/22F
5	1301790017	13611	TENSION LOCK SPRING
6	1302344666	13613	GUIDE - CABLE OUTLET
7	1302344704	AG10310	RET RING-ANDERTON N1500-62:BZP
8	1302261716	M62710002	HANGER BRACKET FOR 10F/15F/22F BALANCER
9	1302344690	580-P-35	EXTERNAL CIRCLIP 0.625" SHAFT
10	1302344712	AG14614	SCREW M4X45LG Posi PHD BZP
11	1302344711	AG14613	SCREW M4X16Lg Posi PHEAD BZP
12	1302344710	AG14612	SCREW M4X10LG Posi PHEAD BZP
13	1302344713	AG14615	M4 NYLOC NUT
14	1301790121	9678-8	8FT/2.4M ASSY CABLE FOR 10/15/22 F&FLR
15	1302344673	14099	WASHER -.63 I.D.x.88 O.D.x.02 W - BZP
16	N/A	N/A	ROUND LABEL SEE PLANT FOR INFO ON P/N
17	1302264648	1240-P-10	TOP SHACKLE ASSY WITH SAFETY PIN
18	SEE CHART	SEE CHART	SAFETY CABLE ASSY SEE CHART FOR USAGE

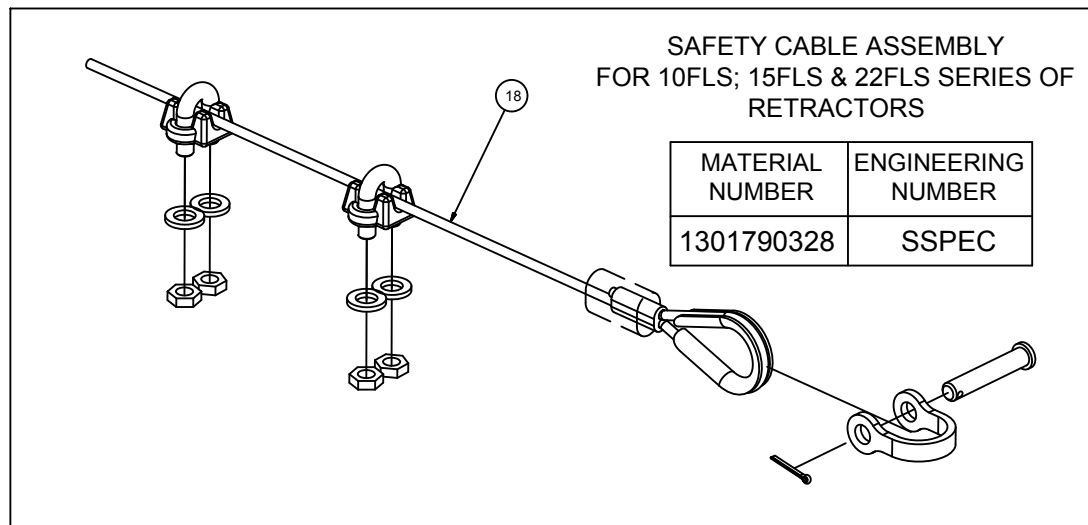

RELEASE TO SALES EC NO: --- DRWN: RHOTCA CHKD: DT APPR: ---	9/17/09 2009/09/17	QUALITY SYMBOLS ▽=0 ▽=0	GENERAL TOLERANCES (UNLESS SPECIFIED)			DIMENSION STYLE IN/MM		SCALE NTS	DESIGN UNITS INCH	THIRD ANGLE PROJECTION
			4 PLACES ±NA ±---	3 PLACES ±NA ±NA	2 PLACES ±NA ±NA	1 PLACE ±NA ±NA	DRAWN BY RH	DATE 2009/09/17	TITLE 10F/15F/22F SERIES OF RETRACTORS	
			ANGULAR ±1°				CHECKED BY DT	DATE 2009/09/17		
			DRAFT WHERE APPLICABLE MUST REMAIN WITHIN DIMENSIONS				APPROVED BY DT	DATE 2009/09/17		
MATERIAL NO. SEE TABLE		DOCUMENT NO. SD-130175-002		SHEET NO. 2 OF 2						
SIZE B		THIS DRAWING CONTAINS INFORMATION THAT IS PROPRIETARY TO MOLEX INCORPORATED AND SHOULD NOT BE USED WITHOUT WRITTEN PERMISSION								