



IMPORTANT SAFETY INSTRUCTIONS

Please read this manual carefully and follow its instructions. Improper use or failure to follow these instructions could result in serious injury, death or property damage. Operators should be instructed in the safe and proper use and maintenance of this product. Keep this manual for future reference.

The following safety precautions call attention to potentially dangerous conditions.



DANGER: Immediate hazards which **WILL** result in severe personal injury or death.



WARNING: Hazards or unsafe practices which **COULD** result in severe personal injury or death.



CAUTION: Hazards or unsafe practices which **MAY** result in *minor* personal injury or product or property damage.

NOTE: Instruct operators in the safe, proper use and maintenance. Keep this manual for future reference.

INSTALLATION



WARNING: Failure to read, understand or follow these instructions could lead to hazards or unsafe practices **COULD** result in severe personal injury or death.



CAUTION: Instruct operators in the safe, proper use and maintenance of this product. Hazards or unsafe practices **MAY** result in *minor* personal injury or product or property damage.

NOTE: Fuse protection should be used and must not be greater than maximum reel amperage rating.

MOUNTING

Reel may be mounted on ceiling, wall, or in any position, as long as main shaft of reel is horizontal. When possible, mount reel within two feet of an electrical outlet. For locations of more than two feet, use a three-conductor extension cord, with wire size equal to or larger than on reel. Use mounting bracket as a template for location of 1/4" screw holes. Template dimensions are 3-11/16" by 7/8", center to center.

SECONDARY SAFETY CABLE



DANGER: A secondary safety cable or chain is to be attached to reels mounted overhead to prevent reel from falling. Immediate hazards **WILL** result in severe personal injury or death.

A 3/16 hole is provided on the base of reel to permit installation of a secondary support chain. All reels mounted over head should have a secondary support chain to protect personnel in case of structure or mounting component failure. Attach one end of secondary support chain or cable to secondary support point and the other to a support component other than that which supports the reel. Chain or cable should be as short as possible allowing reel to drop no more than 6 to 12 inches if primary connection is released. Supports are offered as an accessory item.

WIRING



WARNING: Do not disconnect green wire, the green wire has been grounded to the frame on all models and cannot be used as a power conductor. Hazards or unsafe practices **COULD** result in severe personal injury or death.

All internal wiring has been completed at factory. Reels equipped with handle and guard are ready for installation.

OPTIONAL AUTOMATIC SWITCH

When cable is retracted into reel, ball stop will trigger switch to shut off power. To install, remove screws from cable guide, place switch over guide and replace screws. Plug cord from reel into switch. Then plug cord from switch into power source (Kit D).

ADJUSTMENT

TENSION ADJUSTMENT



CAUTION: To prevent spring damage test for proper spring revolutions. Hazards or unsafe practices **MAY** result in *minor* personal injury or product or property damage.

NOTE: Tension adjustment can be performed before or after installation of reel & can be can be adjusted after all electrical connections are made.

To adjust tension, hold the main shaft by placing a wrench on the flats provided on the protruding end of shaft. Hold wrench firmly while pulling out on the lock pin knob and turn the shaft with wrench clockwise to increase tension or counterclockwise to decrease tension. After adjusting tension, carefully pull the cable all the way out to be sure the spring does not bottom out before the cable is fully extended.

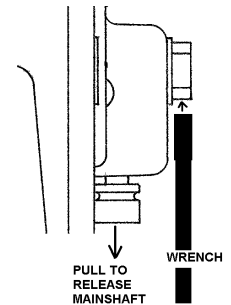

RATCHET LOCK

NOTE: Ratchet lock may be disengaged for constant tension.

Engage lock release lever by turning lock release knob counterclockwise while pulling cable in and out slightly. Ratchet lock can engage about every 6" of cable travel. Pull cable to desired location and let cable retract slightly until lock engages. To release lock, pull cable out slightly.

OVERHANG

Overhang will reduce active cable travel. Adjust ball stop by loosening cable clamp and slide ball stop along cable until light hangs at desired length when cord is fully retracted. Tighten cable clamp.

SERVICE



WARNING: Disconnect power or unplug supply cord before attempting any service. Hazards or unsafe practices **COULD** result in severe personal injury or death.



WARNING: Remove all spring tension before attempting any service. Secure broken spring by welding or wire wrapping in four (4) locations (equally spaced). Hazards or unsafe practices **COULD** result in severe personal injury or death.

MAIN SPRING REPLACEMENT



WARNING: Spring is dangerous. Always wear gloves. Before removing broken spring, weld coils together at four (4) locations or wrap securely with wire. Hazards or unsafe practices COULD result in severe personal injury or death.

Unplug reel and remove ALL tension as described in TENSION ADJUSTMENT section. Remove screw from main shaft & complete cover. Remove shaft-retaining ring and pull tension pin down, then slide complete drum assembly and shaft out of housing. Remove spacer from shaft and remove shaft. Remove nuts from cover then remove cover. Carefully remove main spring from spool. Replace new main spring in drum. Be sure spring hook engages on lip of drum. Reverse the above procedure to reassemble. Be sure shaft engages hook on spring when reassembling. See Illustrations below.

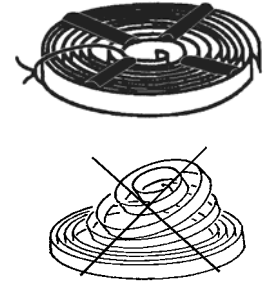

WORKING CABLE REPLACEMENT

Unplug reel and remove ALL tension as described in TENSION ADJUSTMENT section. Remove screw from main shaft & pull off cover. Remove shaft-retaining ring and pull tension pin down, **then slide complete drum assembly and shaft out of housing.** Carefully slide slip ring assembly out of drum and disconnect wires from slip ring ass'y. Unwind cable and then loosen drum clamp. Remove cable with grommet. Slide cable out through cable guide from housing. When equipped with hand lamp or fluorescent lamp, remove from cable (see hand Lamp replacement instructions below). Replace old cable with new cable and reassemble by reversing the above procedure.



SLIP RING & BRUSH REPLACEMENT



WARNING: Check reel for proper continuity, polarity and grounding before connecting power. Hazards or unsafe practices COULD result in severe personal injury or death.

Remove tension as described in ADJUSTMENT. Remove screw from main shaft & remove cover. Slide slip ring from shaft and remove wiring. Rewire and replace slip ring by reversing the procedure. Remove brush plate. Be sure to rewire in the same order as before. Remove ground screw and terminal from lead-in cable. Then, remove screws and brush plate with springs and pins. Remove brushes by removing screw and hardware with leads from lead in cable. Replace brush assembly and lead wire in same order as disassembly. Reverse the above procedure to reassemble. Be sure to replace springs between plate and cover.

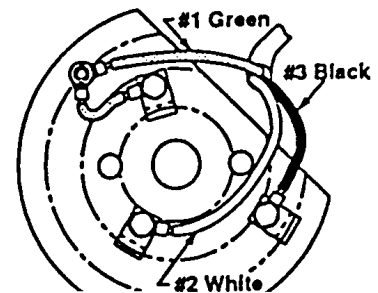

RATCHET LOCK REPLACEMENT

Unplug reel and remove ALL tension as described in TENSION ADJUSTMENT section. Remove screw from main shaft & pull off cover. Remove shaft-retaining ring and pull tension pin down, then slide complete drum assembly and shaft out of housing. Remove retaining ring and unclip spring of ratchet lock from housing. Reverse the above procedure to reassemble.

HAND LAMP REPLACEMENT & INSTALLATION



WARNING: Check reel for proper continuity, polarity and grounding before connecting power. Hazards or unsafe practices COULD result in severe personal injury or death.



WARNING: Disconnect power or unplug supply cord. Hazards or unsafe practices COULD result in severe personal injury or death.

Incandescent: Remove guard and bulb. Remove screws from sides of handle. Remove cable stop assembly, bumper, spring, ball, and cable wiring. Strip wire as needed and wire cable to replacement handle: black to brass screw, white to silver screw, and green to green screw. Reverse the above procedure to reassemble.

Power Cord or Transform Assembly: Remove bolt to open reel cover. Remove the wires that connect the power cord/transformer assembly wires to the brush plate. Attach the lugs on the new cord/transformer assembly wires to the brush assembly. Reassemble the reel.

13W Florescent: Disassemble new hand lamp. Strip the black and white wires from the cord and tin ends. Cut and remove the green wire as close to the outer jacket as possible. Press replacement lamp into connector until firmly retained. Push stripped and tinned wire leads into quick-connect wiring holes in bottom of connector. Slide replacement lamp into protective tube so that the end of the lamp is seated in the end of the tube. Slide tube and lamp assembly into the handle while pulling cord until tube and lamp are seated. Secure tube with screws in sides of handle. Replace nut, plastic washer, and rubber strain relief onto lamp handle.

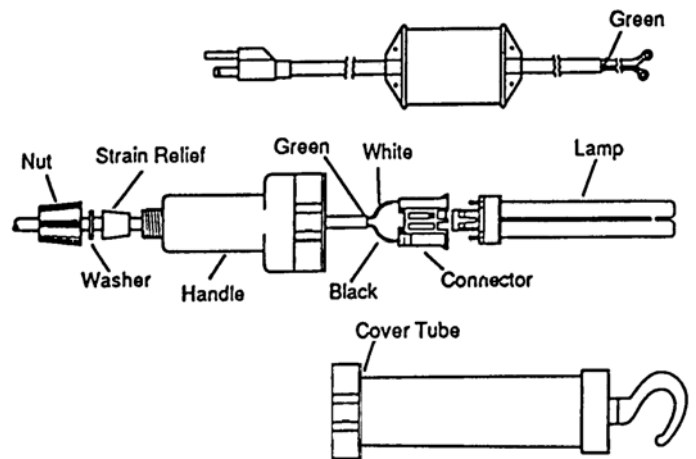

13G Florescent: Disassemble new hand lamp. Strip the black and white wires. Cut and remove the green wire as close to the outer jacket as possible. Pull cable through end cap. Use wire nuts to connect to hand-lamp lead wires. Make sure wire seated properly in the socket base. Use long screws to reassemble socket base. Slide replacement lamp into socket and protective tube over lamp. Use short screws hold on tube. Push end cap all the way on to socket end while pulling cord back through until tube and lamp as necessary.

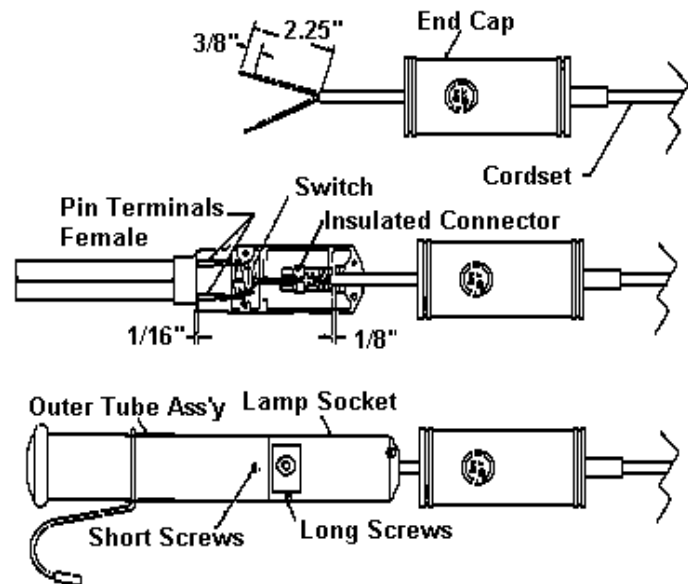

REPLACEMENT PARTS

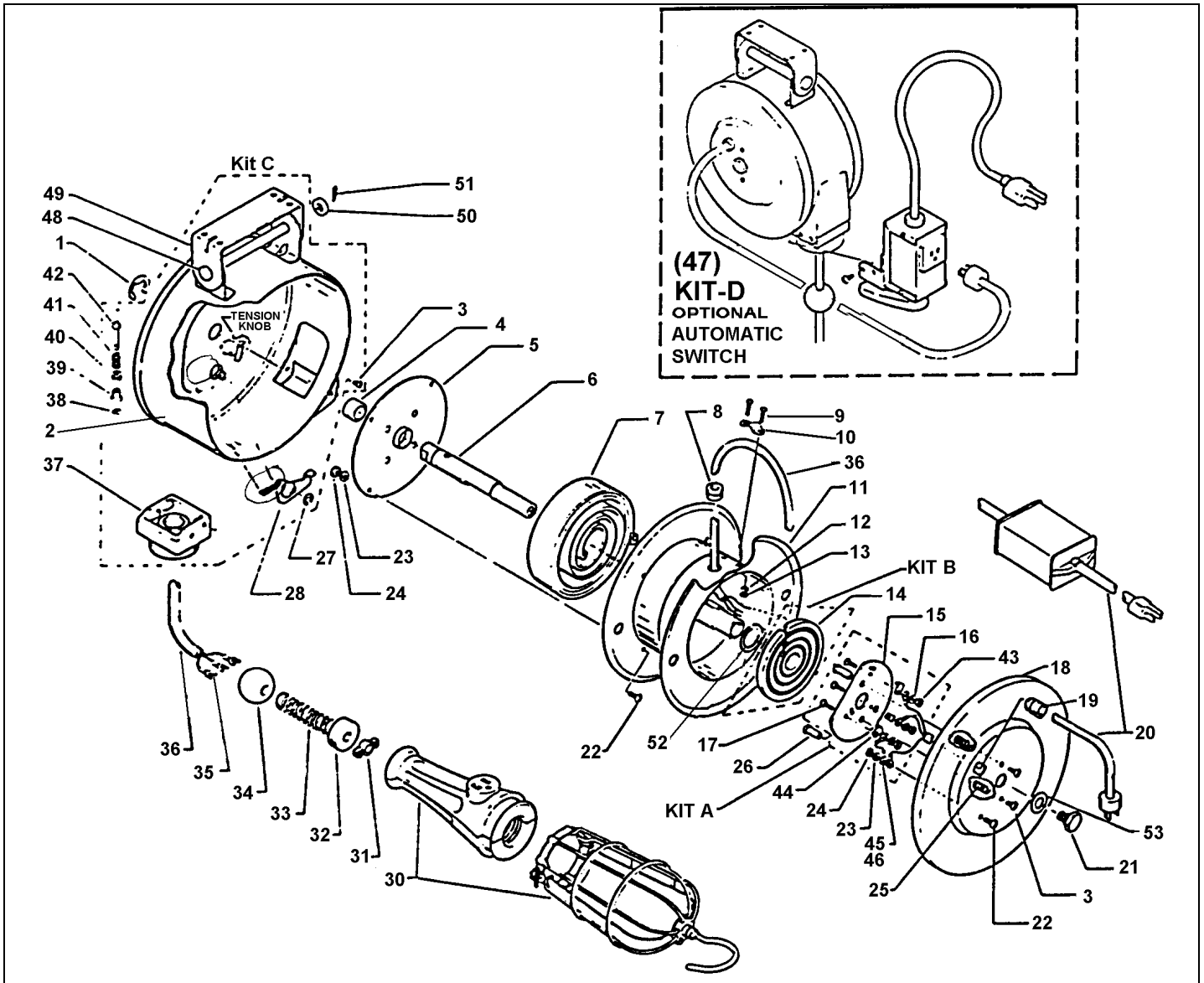

Ref. No.	Part No.	Qty.	Description
1	00580P0050	1	Retaining ring (.500 shaft)
2 (Kit C)	H22520007	1**	Housing & lock Assembly (included: 3, 27, 28, 37, 38, 39, 40, 41, 42, 48, 49)
3	01137P0060	6	Screw self-tap (#8 x 3/8")
4	3127400000	1	Bushing
5	0208500000	1	Cover plate assembly
6	0207400000	1	Main shaft
7	0208000346	1 *	Main spring
8	00701P0010	1	Grommet (3/8" cable @ 1/2" hole)
9	00002P0202	2	Screw round head (#6-32 x 1/2")
10	0004800000	1	Cable clamp
11	0330600000	1	Drum assembly
12	00103P0020	1	Lock washer
13	00151P0015	1	Nut (#6-32)
14	H96310001	1	Slip ring assembly
15	M84780004	1	Brush plate

Ref. No.	Part No.	Qty.	Description
16	00103P0035	3	Lock washer int. Th. (#8)
17	00002P0901	3	Screw - brass (#8-32 x 7/16")
18	0303400000	1	Cover
19	00916P0003	1	Strain relief (.625 DIA. Hole)
20	6234600003 Incl. W/ #30	1	Lead-in cable (RI453, RI453H, RI453M, RI453FE, RI4513S) Lead-in cable (RI4513W, RI4513G)
21	0207100000	1	Screw, main shaft
22	00002P0101	5	Screw (#8-32 x 5/16")
23	00103P0035	6	Washer (#8)
24	00151P0085	5	Nut (#8-32)
25	00600P0010	2	Spring
26	M82310002	2	Pin aligning
27	00580P0030	1	Retaining ring (.375 shaft)
28	0967400000	1	Kit; Spring was wrong number H05000010
30	C89440002 C89440005 C89440011 H81420037 H81420038 C89480118	1	Hand lamp handle and guard (RI453-H)(shown) Hand lamp handle and guard (RI453-FE and FES) Hand lamp handle and guard (RI453-M and MS) Hand lamp Complete plus item #20 (RI45-13W and -13WS) Hand lamp Complete plus item #20 (RI45-13G and -13GS) Hand lamp Complete plus item #20 (RI45-13S)
31	0009500000	1	Cable stop assembly
32	0202500001	1	Bumper
33	0202400001	1	Spring
34	0004700001	1	Ball
35	00047P0001	3	Terminal (RI-45-3H)
36	M10720062	1 *	Working cable
37	0333900000	1	Cable guide
38	00580P0020	1	Retaining ring (.187 shaft)
39	0207800000	1	Knob, lock pin
40	0207600000	1	Bushing, lock pin
41	0207500000	1	Spring
42	0207700000	1	Lock pin, tension
43	00152P0006	3	Nut (#8-32)
44	5786700000	3	Brush
45	00041P0050	2	Terminal
46	01149P0050	A/R	Wire - green
47 (Kit D)	01026P0012	A/R	Automatic switch - optional
48	0200600000	1	Pin
49	02009000YE	1	Swivel mounting bracket
50	C01010222	1	Washer
51	00228P0010	1	Cotter Pin
52	0981300000	1	Washer
53	3123400000	1	Washer
Kit A	H92110001	A/R	Brush plate assembly (inc. 15, 16, 17, 43, 44)
Kit B	H92110002	A/R	Slip ring and cable assembly (inc. 14, 36)

* - Recommended spare parts,

Aero-Motive Company

W A Woodhead Industries Inc. Subsidiary
PO Box 2678
Kalamazoo, MI 49003-2678
USA
(269) 337 7700 / (800) 999 8559
FAX: (800) 333 6119
www.aeromotive.com
techhelp@aeromotive.com

Woodhead Connectivity LTD.

W A Woodhead Industries Inc. Subsidiary
Factory No. 9
Rassau Industrial Estate
Ebbw Vale Gwent NP23 5SD
United Kingdom
44-1495-356300
FAX: 44-1495-356301
sales@wdhd.co.uk

Woodhead Asia PTE LTD.

W A Woodhead Industries Inc. Subsidiary
No. 4 Toh Tuck Link
Level 3 Mezzanine
Markono Logistics Bldg.
Singapore 596226
65-6-261-6533
FAX: 65-6-261-3588
sales@wasia.com.sg

Woodhead Canada LTD.

W A Woodhead Industries Inc. Subsidiary
1090 Brevik Place
Mississauga Ontario
L4W 3Y5 Canada
(905) 624-1079
FAX: (905) 624-9151
www.woodhead.ca