



**AERO-MOTIVE®
PRODUCTS**

CABLE REELS

Aero-Motive® Products: Mobile connectivity solutions for a full range of industrial applications

Get the power to perform with the most advanced cable reels in the industry. Made with precision electrical and mechanical components, Aero-Motive reels are designed to provide top performance, long service life and ease of maintenance. With a huge selection of sizes, styles and related accessories, you get the mobile connectivity solutions you need.

For more information check us out on the web at:
www.woodhead.com

CORD REELS & LAMPS

Pages 5-7

Cord Reels

Description: Cord Reels are spring retractable, industrial reels that are used to keep hand lamps and power outlets accessible and out of the way.



Applications: Portable power supplies, mobile material handling equipment, portable lighting, and machining.

- Available with a variety of optional hand lamps
- Up to 50 feet of cord - up to 250 volt duty
- Swinging or rigid mount
- Adjustable tension
- Built in ratchet locks
- UL Listed and CSA Certified
- 3 Conductor 16 AWG cable (4 Conductor 18 AWG cable model available)

Page 4

Hand Wind Reels

Description:

Manually operated reels for storage and retrieval of extension cords, power cables, ropes or hoses. Three models to choose from.



Applications: Power source for portable tools, lights, fans, or pumps.

- Portable or fixed-mount
- Up to 100 feet of 3-conductor #12, #14 or #16 AWG cable
- Optional power receptacle or slip ring
- Indoor or outdoor applications

HAND WIND REELS

Pages 33-35

Accessories

Pivot and Swivel Base for directional flexibility. Cable Guides, Connectors and Grips to extend cable life.



Automatic Switches and Junction Boxes for safety and convenience.

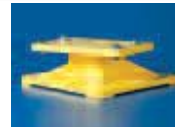

Service options for Mill Duty, Marine, Hazardous locations.



ACCESSORIES

Pages 28-32 Specialty Reels



Welding Reels payout and retract arc welding cable.

SPECIALTY

Pages 8-9

Pow-R-Mite® Cable Reels

Description: Easy to order Pow-R-Mites® are spring-powered cable reels that come equipped with cable installed. Two frame sizes are available with cable capacity of up to 70 feet.

Applications: Use where a movable power supply is required including mobile electrical equipment, portable lighting or power tools. The fixed mount units are suitable for indoor or outdoor use.

- Containerized mainspring for easy replacement
- Available with up to 12 conductors
- Modular collector ring
- Adjustable built in cable guides
- Corrosion resistant surface



Pages 10-27

Pow-R-Matic® Cable Reels

Description: "Assembled-to-Order" Pow-R-Matic® Reels can be fitted with the exact amount and type of cable you require. Frames can accommodate up to 320 feet of #16 AWG cable or up to 180 feet of #1 cable. Precision Collector Rings can be specified for up to 36 conductors. Single or dual main springs are containerized for quick change and easy adjustment.



Applications: Use for power and/or control to mobile industrial equipment such as cranes, hoists, transfer devices, etc.

- Containerized main spring
- External tension adjustment
- Quick change spring motor
- NEMA-4 enclosures for indoor or outdoor use
- Anti-lock-out ratchet system

Pages 35-47 Tech Info

Cable Selection:

Aero-Motive provides information and charts to help you select the right cable for the job. Details such as cable diameter, weight, operating conditions, AC & DC motor current loads and magnet sizes are taken into consideration.

Reel Dimensions:

Complete dimensional information is detailed for all Pow-R-Matic Reels.



Static Discharge and Ground Fault Reels for in plant and electric utility vehicle safety.



Retractors, Balancers and Torque Reels keep pendant stations, connectors and lights up and out of the way.

Hand Wind Reels

Hand wind reels are designed for heavy duty industrial storage applications. Perfect for storing extension cords, or continuous power service.

HW100 HAND WIND REEL

- Heavy duty design for storage of extension cords, power cables, rope or hoses
- Center cavity access to the end of conductor

HW200 HAND WIND REEL

- 15 Amp duplex receptacle on reel and plug on free end of cable
- Point of use
- Disconnecting electrical device is required to wind or unwind cable

HW300 HAND WIND REEL

- Equipped with slip ring, power cable, and plug
- Payout cable has receptacle
- Ideal for continuous service

Maximum capacity- all models

- 3 cond. #16 AWG SO (.430 in. dia.) 200 Ft.
- 3 cond. #14 AWG SO (.560 in. dia.) 125 ft.
- 3 cond. #12 AWG SO (.640 in. dia.) 100 ft.
- usable spool vol. 500 cu. in.

3 cond. Type SO Cable Size	length ft.	m	Amperage cord off reel	Series-UL listed/CSA certified		
				HW100	HW200	HW300
#16 AWG	50	15.24	10	HW122	HW222	HW322
#16 AWG	100	30.48	10	HW124	HW224	HW324
#14 AWG	50	15.24	15	HW132	HW232	HW332
#14 AWG	100	30.48	15	HW134	HW234	HW334
#12 AWG	50	15.24	15	HW142	HW242	HW342
#12 AWG	100	30.48	15	HW144	HW244	HW344
Cable Not Supplied			15	HW100	HW200	HW300

All rated at 125 volts.

HW200 Series Shown

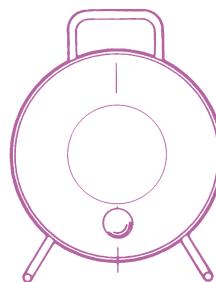

HW100

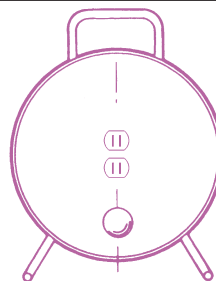
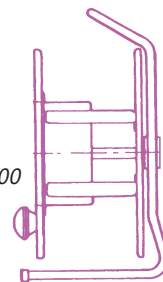

HW200

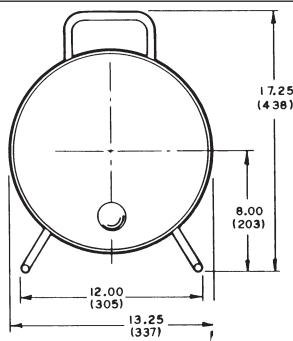
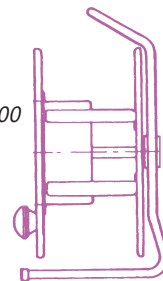

HW300

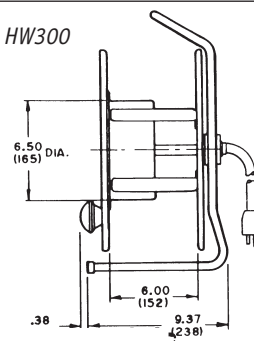

Cord Reels

Cord reels are designed for indoor maintenance, repair, power supply to hoists and close-up work. Ideal for ready access to hand lamps and power outlets.



RI45 CORD REEL

- 35 feet travel
- Swinging mount
- Adjustable tension
- 3 conductor, 16 AWG
- For Hand Lamp, add suffix M, H, 13W, 13G, 13S or FE (see page 7)
- UL listed and CSA certified

CORD REEL SELECTOR CHART RI45

Accessories	35 ft. of Cable 3c/#16 AWG 7a/120v
No Accessories	RI453
Type M Lamp	RI453-M
Type H Lamp	RI453-H
Type FE Lamp	RI453-FE
Type 13S Lamp	RI453-13S
Type 13G Lamp	RI453-13G
Type 13W Lamp	RI453-13W
5 -15R Receptacle	RI453-R
Quad Tap Box	RI453-Q
GFCI Dual Outlet Box	RI453-D

Swing mount standard on all RI45 models.

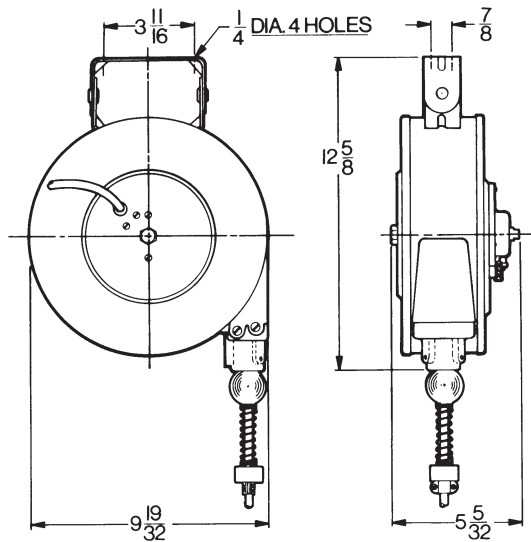

RI 50 CORD REEL

Industrial strength reel has all the convenience, endurance and reliability feature you need at an easy-to-buy price.

- Fewer moving parts for long working life
- Removable hub covers for easy maintenance
- Easy tension adjustment
- Ratchet lock with engage and disengage capability
- Corrosion resistant steel housing
- Rigid or swinging mounts available
- UL listed
- Indoor use only

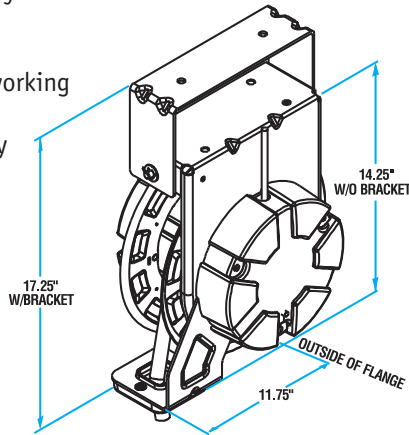

Accessories	50 ft. of Cable 3c/#16 AWG 8a / 120v	45 ft. of Cable 3c/#14 AWG 11a / 120v	35 ft. of Cable 3c/#12 AWG 15a / 120v	50 ft. of Cable 4c/#16 AWG 5.5a / 120v	30 ft. of Cable 4c/#14 AWG 7.5a / 120v
No Accessories	RI51	RI53	RI55	RI52	RI54
Type M Lamp	RI51-M	RI53-M			
Type FE Lamp	RI51-FE	RI53-FE			
Type 13G Lamp	RI51-13G	RI53-13G			
5 -15R Receptacle	RI51-R	RI53-R	RI55-R		
Triplex Outlet Strip	RI51-T				
Quad Tap Box (4) 5-15R	RI51-Q	RI53-Q	RI55-Q		
GFCI Dual Outlet Box (2) 5-15R	RI51-D	RI53-D	RI55-D		

RI50 reels come standard with rigid mount and no hand lamps. To select swinging mount add suffix "S" to part number. To add hand lamp option add the suffix for the type of hand lamp required. Add the suffix "AS" for the auto switch option. Example: RI51S-FE-AS. To add a pivot base option order item# PB10YE. All 3 conductor reels come without plug.

2 2 8 B CORD REEL

- 50 feet travel
- Adjustable tension
- 3 conductor, 16 AWG SO
- Rigid Mount
- UL listed and CSA certified
- For Hand Lamp, add suffix FE, M, or G (see page 7)

Accessories	50 ft. of Cable 3c/#16 AWG	45 ft. of Cable 3c/#14 AWG
Type M Lamp	228B-M	
Type FE Lamp	228B-FE	
Type 13S Lamp	228B-13S	
Type 13G Lamp	228B-13G	
5 -15R Receptacle	228B-R	358C-R
Quad Tap Box (4) 5-15R	228B-Q	358C-Q
GFCI Dual Outlet Box (2) 5-15R	228B-D	358C-D



All 228B and 358C reels come standard with rigid mount. Swinging mount option is not available. Auto switch option is not available. To add a pivot base option order item# PB2A. 228BH, 228BM, and 228B13S reels include 3 ft. of lead-in cable with plug and a cable stop.

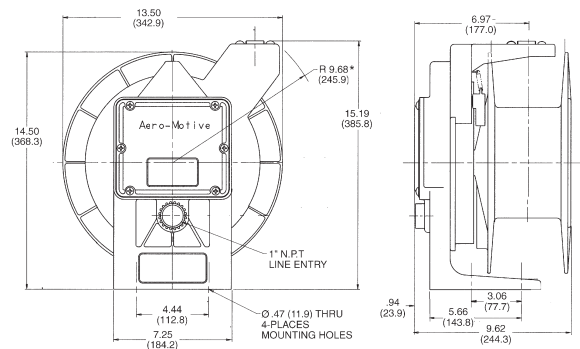

* GUIDE POSITION ADJUSTABLE THRU 270° ARC

Optional Cord Reel Lamps



Type M HAND LAMP DANIEL WOODHEAD®

- Steel guard with reflector for 100W bulb
- Replaceable lamp switch
- NEMA 5-15R outlet
- Rubber handle
- Snap-open guard



Type H HAND LAMP DANIEL WOODHEAD®

- Guard with reflector for 100W bulb
- Replaceable lamp switch
- NEMA 5-15R outlet
- Snap open guard



Type FE HAND LAMP DANIEL WOODHEAD®

- Insulated guard without reflector
- Use with remote or optional auto switch
- Complies with NEC S11-3F



Type 13S HAND LAMP DANIEL WOODHEAD®

- Fluorescent hand lamp
- Built-in ballast
- Low temperature 13 watt lamp



Type 13W HAND LAMP DANIEL WOODHEAD®

- Fluorescent hand lamp
- Low temperature 13-watt lamp
- Use with remote or optional auto switch
- Ballast on cord / inlet side



Type 13G HAND LAMP DANIEL WOODHEAD®

- Fluorescent hand lamp
- Low temperature 13-watt lamp
- Use with remote or optional auto switch
- Built-in ballast

Other Cord Reel Accessories

RECEPTACLE One NEMA 5-15R outlet (add suffix -R)

TRIPLEX OUTLET Three NEMA 5-15R outlets (add suffix -T)

DUAL OUTLET Two 15A GFCI outlets, snap door cover (add suffix -D)

QUAD OUTLET Four NEMA 5-15R outlets (add suffix -Q)

PIVOT BASE (see page 9) 330° pivot - order PB10YE for RI50 series reels and PB2A for 228B

AUTOMATIC ON/OFF SWITCH Turns light off when cable is fully retracted (Available on RI50 cable reels only)

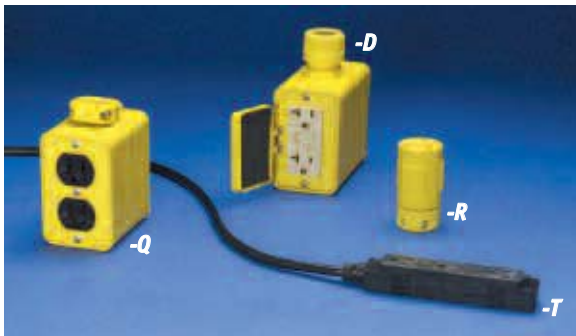

Pow-R-Mite® Cable Reels

Cable reels are designed for top performance, long service life and easy maintenance. Ideal for hoists, electric tools and moving equipment.

- Factory assembled with Type S0 or W cable
- Reels constructed with spring tension to lift or stretch cable with no more than 10% sag
- Containerized main-spring for safe, easy handling
- Modular collector ring
- 30 Amp collector ring on 200, 300, & 400 models
- 35 or 75 Amp collector ring on 5000 models
- Adjustable cable guide with anti cable "lock-out"
- UL listed and CSA Certified

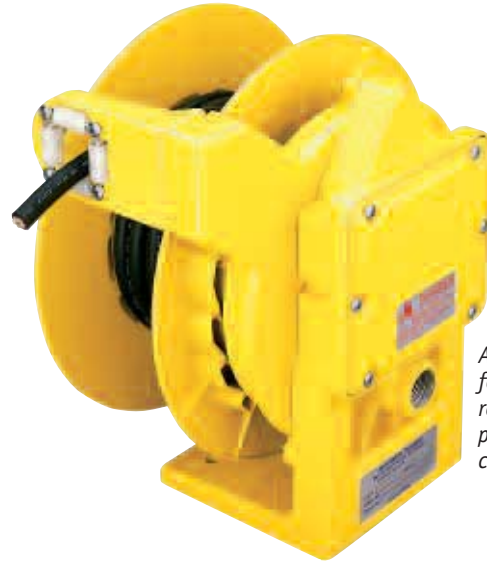

Aero-Motive reels feature corrosion resistant powder-polyester surface construction.

Selecting Pow-R-Mite Reels

- Determine cable size (AWG), number of conductors required and travel distance
- Locate model number in chart on page 9
- Consider accessories needed
- Order model number

Cable is included on all Pow-R-Mite models. Specify by number of conductors, AWG size and length.



Compact 30, 35 or 75 amp modular collector rings can accommodate up to 16 conductors. All brushes are spring loaded copper/ graphite for positive electrical contact.

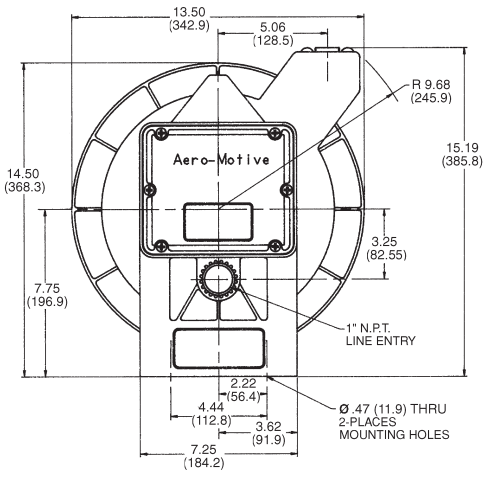

Series 200, 300, 400

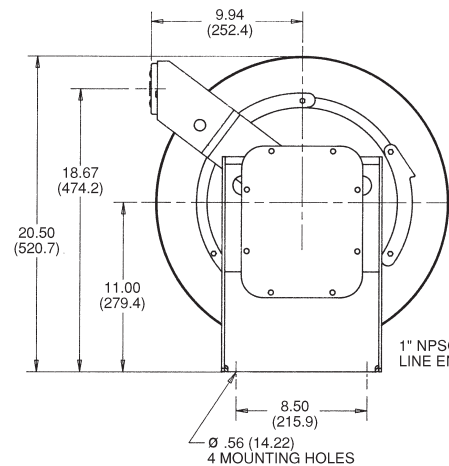
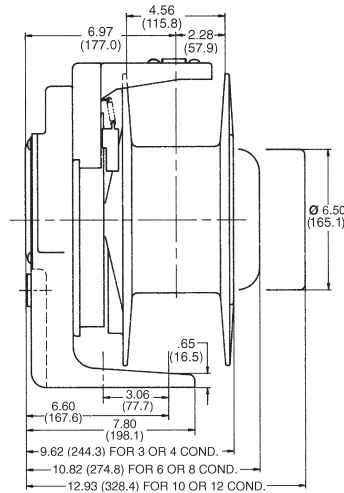

Series 5000M

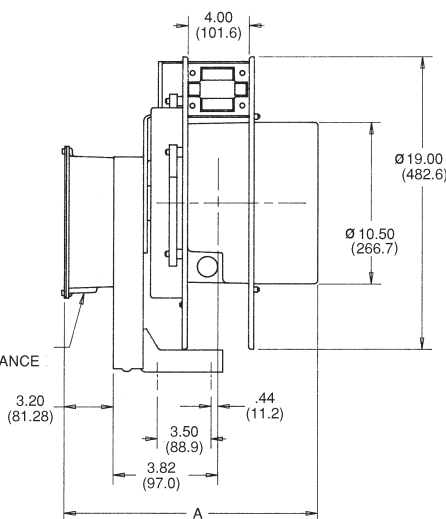

Models	Dim. A (in)
#16 - 10 AWG (2 - 6 Cond.)	16.67
#16 - 10 AWG (8 - 12 Cond.)	18.84
#8 - 6 AWG (2 - 3 Cond.)	16.67
#8 - 6 AWG (4 Cond.)	18.84

POW-R-MITE SELECTOR

For easy selection, choose amperage, cable size, number of conductors and cable length from shaded area below.

Rated Amps.	Cable AWG Size	No. Cond.	Length Feet/Meters									
			20/6.1	25/7.6	30/9.1	35/10.7	38/11.6	40/12.2	45/13.7	50/15.2	60/18.3	70/21.3
9	16	3	232B*		224B*				231B*		228B*	5137BL*
7	16	4	242B		234B				244B		238B	5147BL
7	16	6								206B		5167BL
6	16	8					208B				485B	5187BL
5	16	10			403B						5105BL	5207BL
5	16	12			413B						5115BL	5217BL
13	14	3	332C**	253C**	233C**				334C**		358C**	5137CL**
11	14	4	342C	363C	343C				344C	367C	345C	5147CL
11	14	6				306C					5165CL	5267CL
8	14	8	308C		483C							5286CL
7	14	10	402C								5205C	
6	14	12	5112CL						5214CL			
18	12	3	332D	383D	333D	385D			434D		435D	5137DL
14	12	4	342D		394D				444D		445D	5146DL
14	12	6			463D							5266DL
12	12	8	482D								5285DL	
22	10	3	242E		433E				434E		5135EL	5237EL
16	10	4	452E		443E				5144EL		5245EL	5247EL
14	10	6	462E								5365EL	
14	10	8			5283EL							
40	8	2			5123FL						5225FL	
35	8	3			5133FL						5235FL	
32	8	4	5142FL						5344FL			
55	6	2			5223GL						5325GL	
45	6	3			5333GL							
44	6	4	5342GL									

End of Cable options (see page 7)

*Q, R, D, M, H, 13S

**Q, R, D

Pow-R-Mite Accessories

PB Series PIVOT BASE

■ Allows cable and cord reels to rotate 330°

Model	Reel Series	Dim.A in. mm	Dim.B in. mm	Dim.C in. mm	Dim.D in. mm	Dim.E in. mm	Dim.F in. mm
PB10YE	RI50	3	4	2.69	0.50	0.438	1.25
		76	102	68.3	13	11.13	31.8
PB2A	200/300	3	4	1.44	0.50	0.438	0.25
	400	76	102	36.6	13	11.13	6.4
PBM7A	5000	10	11.5	3.76	0.75	0.531	0.63
		254	292	95.5	19.1	13.49	15.9

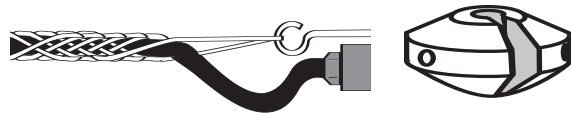
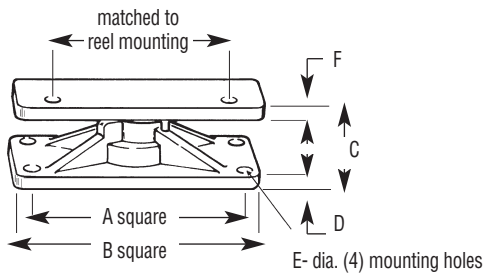

CABLE GRIPS AND STOPS

Cable Size OD, ins.	Cable Grip Model	Cable Stop Model
0.30-0.41	36562	ST1
0.41-0.56	36564	ST1
0.57-0.70	36567	ST1
0.70-0.75	36569	ST1
0.75-0.82	36569	ST2
0.82-0.875	36571	ST2
0.875-1.00	36571	ST3
1.06-1.25	36574	ST3



Pow-R-Matic® Cable Reels

Cable reels are designed for top performance, long service life and easy maintenance. Ideal for hoists, electric tools and moving equipment.

- Custom assembled with modular components
- Order without cable or fitted with exact cable length needed
- Containerized main spring for safe and easy handling
- Self-contained collector ring for simple installation and service
- Driving and declutching spring hub protects springs from damage when cable is installed or in the event of broken cable.
- External tension adjustment allows tension adjustment to be completed in minutes. Available on series 2000 through 2800. See page 28.
- Quick change spring motor reduces down time. Standard on all Series 2000 reels.
- NEMA-4 electrical enclosures
- Anti-lock-out ratchet system available on series 0900 & 1000M prevents reel lock out when cable is fully extended
- Cable reel accessories available on pages 33-35.



Frame Size

Pow-R-Matic Reels are available in over 10 frame styles, defined as "Series" in this catalog. Within each series are dozens of size variations that accommodate various cable lengths and diameters. The charts on the following pages make it easy to order the right reel for the job. All frames are engineered for long-term, trouble-free service. Optional components can be added to the frame for mill duty, hazardous locations or marine service. Four roller guides are standard on Series 0900 and 1000M. Larger reels feature guide rails that can accommodate optional guides.



Self-contained main springs are lubricated for life at the factory.

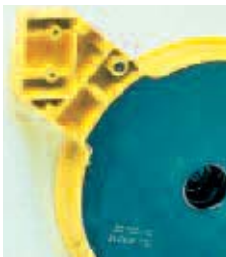

Main Spring

All Aero-Motive reels are powered by individual or dual flat spring steel mainsprings. The unique self-contained precision springs are lubed for life. Maintenance is easier and safer with the external tension adjustment feature and the declutching spring hub. An interchangeable quick-change spring motor is standard on all Series 2000 - 2800 reels.

Collector Ring

The heart of every Pow-R-Matic Reel is the collector or slip ring. All Aero-Motive collector rings are engineered to more than meet the electrical requirements of the cable. Four styles handle from 30 to 200 amps, 3 to 36 conductors.

Modular brush holder assembly is made with non-conductive phenolic holders that are mounted at two points for assured alignment. Stainless steel compression springs provide constant contact for the copper graphite brushes and copper alloy rings. Silver components can be ordered for low level communication signals.



Selecting Pow-R-Matic Reels

Pow-R-Matic Reels are assembled from modular components to your specific application requirements. Follow these four simple steps to order the reel that fits your needs.

1 **No. 14 Cable**

No. of Cond.	20 ft 6.1 m	30 ft. 9.15 m	40 ft. 12.2 m	50 ft. 15.25 m	60 ft. 18.3 m	70 ft. 21.35 m	80 ft. 24.4 m
3	0951-05-203	0951-05-203	0951-05-203	0951-05-203	1051-01-303	1051-01-303	1051-01-303
4	0951-05-204	0951-05-204	0951-04-204	0951-04-204	1051-01-304	1051-01-304	1051-01-304
6	0951-05-206	0951-05-206	0951-04-206	1051-01-306	1051-02-306	1051-02-306	1143-16-306
8	0951-05-208	0951-04-208	1051-02-308	1051-02-308	1051-02-308	1143-16-308	1164-05-308
10	0951-04-210	1051-01-310	1051-02-310	1051-02-310	1163-16-310	1253-05-310	1253-05-310

Step 1 Select Conductor Size

Cable must be capable of handling the full operating load of all equipment which can be operated concurrently (total connected horsepower). Turn to the page spread that features your size selection.

SPECIAL CABLES: Pow-R-Matic Cable Reels can be used with stainless steel braided, silicone, or reffasil insulated cables. For cables designed for extreme temperatures, consult the factory for reel recommendations.

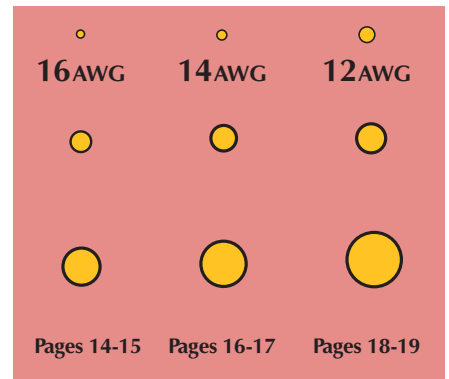

Step 2 Determine Your Application

Reels within each page are grouped by application. See the explanation below and match it with the application grouping on the selector chart.

Step 3 Select The Number of Conductors and Type of Cables

Determine the number of control or power functions required. Extra conductors should be considered for future use.

Reels are cataloged based on Type S0 for control cables and Type W and G for power. Refer to page 36 for further cable information.

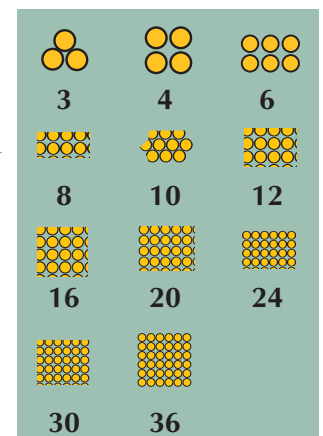

Step 4 Determine Length of Active Cable

Finally, select the desired length of active cable by feet (in black type) or meters (in blue). Actual cable must be ordered separately.

Active cable longer than 50 ft. will have too much tension to be pulled out manually.

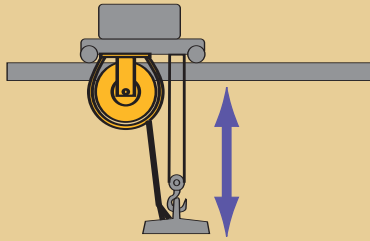

Vertical Lift:

Reel is mounted overhead. Cable pays out downward and is retracted up via spring power. Reel must have enough tension to lift the total weight of the cable and any additional weight attached to it, e.g., pendent station, cable overhang. The exact weight of added equipment must be known, as standard reels are designed to lift weight of specified length of cable only.

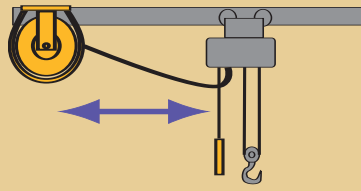

Horizontal Stretch:

Cable is suspended in the air, supported at both ends. The tension must accommodate about twice the total weight of the cable to maintain an acceptable 6% sag. The greater the allowable sag, the less tension required, allowing dollar savings to the user.

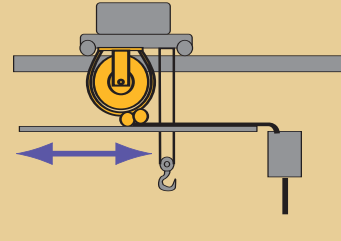

Recovery:

Mounted on a moving carrier, reel picks up cable from stationary base. The closer the reel is to the recovery surface, the less tension is required.

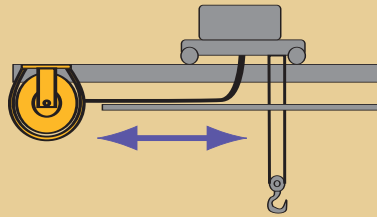

Drag:

The reel is mounted in a permanent location. Cable is dragged over surface to and from fixed mounted reel. The tension required is about the same as the lift application.

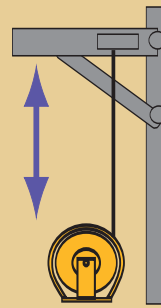

Vertical Recovery:

Base mounted reel pays out cable upward. The reel is required only to recover the cable on the spool, as the cable moves downward. Minimal tension is needed to recover cable into the reel.



Example

In the example illustrated above, a job called for a reel with #14 AWG wire(1) used in a lift application(2). Six conductors were required (3) and the active travel was between 50 and 60 feet (4). The best reel for the job is model 1051-01-303.

Optional features can be ordered by including the appropriate suffix to the model number:

- L for a ratchet lock (models 1100M through 1400M),
- MD for mill duty service option (models 2000 through 2800), see page 28.

- X for hazardous location (models 1100M through 2800)

See pages 33-35 for more information on these and other accessories.

No. 16 Cable

Cable rated at 600 volts

ALL MODELS ARE LESS CABLE

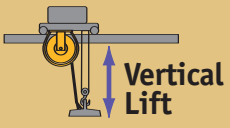
Application	Number of Conductors	Length of Active Cable (feet, meters)							
		20 ft. 6.1 m	30 ft. 9.15 m	40 ft. 12.2 m	50 ft. 15.25 m	60 ft. 18.3 m	70 ft. 21.35 m	80 ft. 24.4 m	
 Vertical Lift	3	0951-05-203	0951-05-203	0951-05-203	0951-05-203	1051-01-303	1051-01-303	1142-10-303	
	4	0951-05-204	0951-05-204	0951-05-204	0951-05-204	1051-01-304	1051-01-304	1051-01-304	
	6	0951-05-206	0951-05-206	0951-05-206	0951-05-206	1051-01-306	1051-01-306	1051-01-306	
	8	0951-05-208	0951-05-208	0951-04-208	0951-04-208	1051-01-308	1051-01-308	1051-01-308	
	10	0951-04-210	0951-04-210	0951-04-210	1051-01-310	1051-02-310	1051-02-310	1143-16-310	
	12	0951-04-212	0951-04-212	0951-04-212	1051-01-312	1142-16-312	1143-16-312	1143-16-312	
	16	1142-10-316	1142-10-316	1142-10-316	1142-16-316	1143-16-316	1163-05-316	1163-05-316	
	20	1142-10-320	1142-10-320	1142-16-320	1142-16-320	1163-05-320	1163-05-320	1164-17-320	
	24	1142-10-324	1142-10-324	1142-16-324	1253-05-324	1253-05-324	1253-17-324	1544-16-324	
	30	1142-10-330	1142-16-330	1142-16-330	1253-05-330	1253-17-330	1354-16-330	1544-16-330	
	36	1142-10-336	1142-16-336	1163-05-336	1253-17-336	1354-16-336	1544-05-336	1546-05-336	

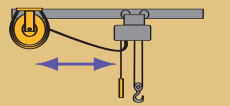
Application	No. of Cond.	Length of Active Cable (feet, meters)							
		20 ft. 6.1 m	30 ft. 9.15 m	40 ft. 12.2 m	50 ft. 15.25 m	60 ft. 18.3 m	70 ft. 21.35 m	80 ft. 24.4 m	
 Stretch	3	0951-05-203	0951-05-203	0951-05-203	0951-05-203	1051-01-303	1051-01-303	1142-10-303	
	4	0951-05-204	0951-05-204	0951-05-204	0951-04-204	1051-01-304	1051-01-304	1051-01-304	
	6	0951-05-206	0951-05-206	0951-04-206	0951-04-206	1051-01-306	1142-10-306	1142-10-306	
	8	0951-05-208	0951-04-208	0951-08-208	1051-01-308	1051-02-308	1143-16-308	1143-05-308	

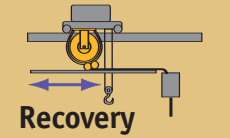
Application	No. of Cond.	Length of Active Cable (feet, meters)							
		50 ft. 15.2 m	60 ft. 18.3 m	70 ft. 21.35 m	80 ft. 24.4 m	90 ft. 27.45 m	100 ft. 30.5 m	120 ft. 36.6 m	
 Recovery (Pickup, Retrieve)	3	0951-05-203	1051-01-303	1051-01-303	1142-10-303	1143-10-303	1143-10-303	1143-10-303	
	4	0951-05-204	1051-01-304	1051-01-304	1051-01-304	1143-10-304	1143-10-304	1143-10-304	
	6	0951-05-206	1051-01-306	1051-01-306	1051-01-306	1143-10-306	1143-10-306	1143-10-306	
	8	0951-04-208	1051-01-308	1051-01-308	1051-01-308	1143-10-308	1143-10-308	1143-10-308	
	10	1051-01-310	1051-01-310	1051-01-310	1143-10-310	1143-10-310	1163-10-310	1253-10-310	
	12	1051-01-312	1051-01-312	1051-01-312	1143-10-312	1163-10-312	1163-10-312	1253-10-312	
	16	1142-10-316	1142-10-316	1163-10-316	1163-10-316	1253-10-316	1253-10-316	1253-10-316	
	20	1142-10-320	1163-10-320	1163-10-320	1163-10-320	1253-10-320	1253-10-320	1443-10-320	
	24	1253-10-324	1253-10-324	1253-10-324	1443-10-324	1443-10-324	1443-16-324	1475-16-324	
	30	1253-10-330	1253-10-330	1253-10-330	1443-05-330	1445-05-330	1443-05-330	1475-05-330	
	36	1253-10-336	1253-10-336	1443-05-336	1443-05-336	1445-05-336	1475-05-336	1475-05-336	

APPLICATION NOTES

See page 12 for application details.

Vertical Lift Loads in addition to cable weight are not included. Lift reels will also drag cables over supporting surface, or stretch cables with 10% sag.

Horizontal Stretch (unsupported) Maximum sag is 6% of total cable length. If 10% sag can be allowed, use LIFT chart.

Recovery (Pickup, Retrieve) Reel is mounted on moving equipment.

Pay-out and recovery can be two-way with power source at mid-point. Typical mounting is 3 ft. from surface to lower reel flange.

Speeds to 200 fpm. For other conditions, contact factory. **If slow moving recovery application (50fpm or less) more tension may be required. Please contact factory for application assistance.**

When ordering, specify cable size and type. Maximum operating speed: 200 fpm.; for other conditions, consult factory. Ratchet lock standard on Series 0900 and 1000M reels. Optional ratchet lock available on Series 1100M through 1400M; Specify by adding "-L" to model number. Junction box data, see page 38; junction boxes are required to comply with CSA specifications. Cable grips are recommended for all applications. See page 37.

90 ft. 27.45 m	100 ft. 30.5 m	120 ft. 36.6 m	140 ft. 42.7 m	160 ft. 48.8 m	180 ft. 54.9 m	200 ft. 61 m	No. of Cond.
1143-10-303	1143-10-303	1143-10-303	1164-10-303	1164-10-303	1255-10-303	1255-10-303	3
1143-10-304	1143-10-304	1143-10-304	1164-10-304	1164-10-304	1255-16-304	Use No.12/4	4
1143-10-306	1143-10-306	1143-10-306	1255-16-306	1255-05-306	1255-05-306	Use No.12/6	6
1143-16-308	1164-16-308	1164-16-308	1255-05-308	1255-05-308	1255-17-308	2058-53-308	8
1163-16-310	1164-05-310	1255-05-310	1255-17-310	2056-53-310	2347-55-310	2348-56-310	10
1163-05-312	1164-05-312	1255-05-312	1255-17-312	2346-55-312	2348-56-312	2348-56-312	12
1253-05-316	1255-17-316	1356-16-316	2346-55-316	2348-60-316	2349-60-316	2477-53-316	16
1255-17-320	1356-16-320	2346-56-320	2347-60-320	2349-63-320	2370-63-320	2477-53-320	20
1546-16-324	1546-05-324	2377-60-324	2379-63-324	2370-65-324	2477-55-324	2478-56-324	24
1546-05-330	1546-05-330	2378-63-330	2370-66-330	2476-55-330	2476-56-330	2479-60-330	30
1546-05-336	2377-63-336	2379-66-336	2476-56-336	2478-60-336	2679-60-336	2670-63-336	36

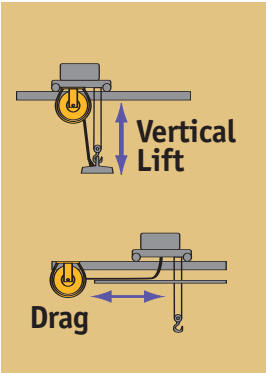

90 ft. 27.45 m	100 ft. 30.5 m	110 ft. 33.55 m	120 ft. 36.6 m	130 ft. 39.65 m	140 ft. 42.7 m	150 ft. 45.75 m	No. of Cond.
1143-10-303	1143-10-303	1143-10-303	1143-10-303	1143-10-303	1255-16-303	1255-16-303	3
1143-10-304	1143-10-304	1143-10-304	1164-16-304	1164-16-304	1255-05-304	1255-05-304	4
1143-16-306	1164-16-306	1164-05-306	1164-05-306	1255-05-306	1255-05-306	1255-17-306	6
1164-05-308	1164-05-308	1164-05-308	1255-17-308	1255-17-308	2056-53-308	2056-53-308	8

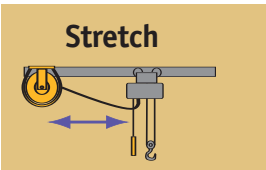

140 ft. 42.7 m	160 ft. 48.8 m	180 ft. 54.9 m	200 ft. 61 m	240 ft. 73.2 m	280 ft. 85.4 m	320 ft. 97.6 m	No. of Cond.
1164-10-303	1164-10-303	1255-10-303	1255-10-303				3
1164-10-304	1164-10-304	1255-10-304	1255-10-304				4
1164-10-306	1165-10-306	1255-10-306					6
1255-10-308	1255-10-308	1255-10-308					8
1255-10-310	1255-10-310	1445-10-310					10
1255-10-312	1443-10-312	1445-10-312					12
1443-10-316	1443-10-316	1445-10-316					16
1443-10-320	1445-10-320	1475-10-320					20
1475-16-324	1475-16-324	1475-16-324					24
1475-05-330	1475-05-330	1475-05-330					30
1475-05-336	1475-05-336	2576-50-336					36

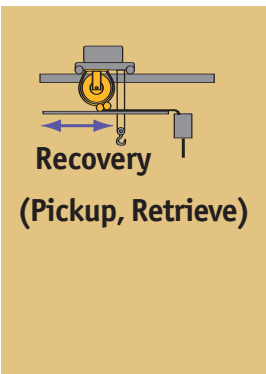

DIMENSIONS

SERIES	0900	1000M	1100M	1200M	1300M	1400M	1500M	2000	2300	2400	2500	2600	2700	2800
PAGE NO.	38	38	39	40	40	41	41	42	43-44	45	46	46	47	47

If cable reel is not found in selection charts, please consult factory.

No. 14 Cable

Cable rated at 600 volts

ALL MODELS ARE LESS CABLE

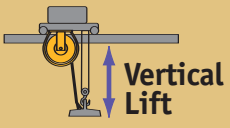
Application	Number of Conductors	Length of Active Cable (feet, meters)							
		20 ft. 6.1 m	30 ft. 9.15 m	40 ft. 12.2 m	50 ft. 15.25 m	60 ft. 18.3 m	70 ft. 21.35 m	80 ft. 24.4 m	
 <p>Vertical Lift</p>	3	0951-05-203	0951-05-203	0951-05-203	0951-05-203	1051-01-303	1051-01-303	1051-01-303	
	4	0951-05-204	0951-05-204	0951-04-204	0951-04-204	1051-01-304	1051-01-304	1051-01-304	
	6	0951-05-206	0951-05-206	0951-04-206	1051-01-306	1051-02-306	1051-02-306	1143-16-306	
	8	0951-05-208	0951-04-208	1051-02-308	1051-02-308	1051-02-308	1143-16-308	1164-05-308	
	10	0951-04-210	1051-01-310	1051-02-310	1051-02-310	1163-16-310	1253-05-310	1253-05-310	
	12	1051-01-312	1051-01-312	1051-02-312	1163-16-312	1164-16-312	1253-05-312	1253-17-312	
	16	1142-10-316	1142-16-316	1163-05-316	1253-05-316	1253-17-316	1354-16-316	1544-16-316	
	20	1142-10-320	1163-16-320	1253-05-320	1253-17-320	1354-16-320	1544-16-320	1546-05-320	
	24	1142-16-324	1163-05-324	1253-05-324	1544-16-324	1544-05-324	1546-05-324	1546-17-324	
	30	1142-16-330	1253-05-330	1544-16-330	1544-05-330	1574-05-330	1576-17-330	2376-65-330	
	36	1163-05-336	1253-17-336	1544-16-336	1544-05-336	1576-17-336	2376-66-336	2378-70-336	

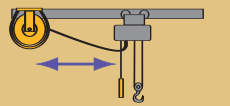
Application	No. of Cond.	Length of Active Cable (feet, meters)							
		20 ft. 6.1 m	30 ft. 9.15 m	40 ft. 12.2 m	50 ft. 15.25 m	60 ft. 18.3 m	70 ft. 21.35 m	80 ft. 24.4 m	
 <p>Stretch</p>	3	0951-05-203	0951-05-203	0951-04-203	1051-01-303	1051-01-303	1051-02-303	1142-10-303	
	4	0951-05-204	0951-05-204	0951-04-204	1051-01-304	1051-02-304	1051-02-304	1143-16-304	
	6	0951-04-206	0951-08-206	0951-08-206	1051-02-306	1143-16-306	1143-05-306	1143-05-306	
	8	0951-04-208	0951-08-208	1051-02-308	1051-03-308	1143-05-308	1143-17-308	1164-17-308	

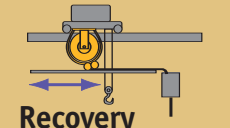
Application	No. of Cond.	Length of Active Cable (feet, meters)							
		50 ft. 15.2 m	60 ft. 18.3 m	70 ft. 21.35 m	80 ft. 24.4 m	90 ft. 27.45 m	100 ft. 30.5 m	120 ft. 36.6 m	
 <p>Recovery (Pickup, Retrieve)</p>	3	0951-05-203	1051-01-303	1051-01-303	1051-01-303	1143-10-303	1143-10-303	1143-10-303	
	4	0951-06-204	1051-01-304	1051-01-304	1143-10-304	1143-10-304	1143-10-304	1143-10-304	
	6	1051-01-306	1051-01-306	1051-01-306	1143-10-306	1163-10-306	1163-10-306	1253-10-306	
	8	1051-01-308	1051-01-308	1143-10-308	1164-10-308	1253-10-308	1253-10-308	1443-10-308	
	10	1051-01-310	1163-10-310	1253-10-310	1253-10-310	1253-10-310	1253-10-310	1443-10-310	
	12	1163-10-312	1164-10-312	1253-10-312	1253-10-312	1253-10-312	1253-10-312	1443-10-312	
	16	1253-10-316	1253-10-316	1253-10-316	1443-05-316	1443-05-316	1445-05-316	1475-05-316	
	20	1253-10-320	1253-10-320	1443-05-320	1443-05-320	1445-05-320	1475-05-320	1475-05-320	
	24	1443-05-324	1443-05-324	1445-05-324	1445-05-324	1445-05-324	1475-05-324	1475-05-324	
	30	1443-05-330	1475-05-330	1475-05-330	1475-05-330	1475-05-330	1475-05-330	2576-55-330	
	36	1544-16-336	1574-16-336	1574-16-336	1576-16-336	1576-16-336	2577-60-336	2578-60-336	

APPLICATION NOTES

See page 12 for application details.

Vertical Lift Loads in addition to cable weight are not included. Lift reels will also drag cables over supporting surface, or stretch cables with 10% sag.

Horizontal Stretch (unsupported) Maximum sag is 6% of total cable length. If 10% sag can be allowed, use LIFT chart.

Recovery (Pickup, Retrieve) Reel is mounted on moving equipment. Pay-out and recovery can be two-way with power source at mid-point. Typical mounting is 3 ft. from surface to lower reel flange. Speeds to 200 fpm. For other conditions, contact factory. **If slow moving recovery application (50fpm or less) more tension may be required. Please contact factory for application assistance.**

When ordering, specify cable size and type. Maximum operating speed: 200 fpm.; for other conditions, consult factory. Ratchet lock standard on Series 0900 and 1000M reels. Optional ratchet lock available on Series 1100M through 1400M; Specify by adding "-L" to model number. Junction box data, see page 38; junction boxes are required to comply with CSA specifications. Cable grips are recommended for all applications. See page 37.

90 ft. 27.45 m	100 ft. 30.5 m	120 ft. 36.6 m	140 ft. 42.7 m	160 ft. 48.8 m	180 ft. 54.9 m	200 ft. 61 m	No. of Cond.
1143-10-303	1143-10-303	1164-16-303	1255-16-303	1255-05-303	1255-05-303	Use No. 12/3	3
1143-10-304	1164-16-304	1164-16-304	1255-05-304	1255-05-304	1255-05-304	Use No. 12/4	4
1163-16-306	1164-05-306	1255-05-306	1255-17-306	2346-55-306	2348-56-306	2348-56-306	6
1253-05-308	1255-05-308	1546-16-308	2346-55-308	2347-56-308	2349-60-308	2370-60-308	8
1255-17-310	1356-16-310	1546-16-310	2347-60-310	2348-60-310	2370-63-310	2477-53-310	10
1356-16-312	1356-16-312	2346-56-312	2347-60-312	2349-63-312	2476-53-312	2476-53-312	12
1546-16-316	1546-05-316	2378-63-316	2370-66-316	2476-55-316	2477-56-316	2679-60-316	16
1546-05-320	2377-63-320	2379-66-320	2476-56-320	2678-60-320	2678-60-320	2670-63-320	20
2347-65-324	2378-66-324	2476-56-324	2677-60-324	2679-63-324	2870-63-324	2870-65-324	24
2378-70-330	2370-76-330	2676-60-330	2678-63-330	2879-65-330			30
2370-76-336	2676-60-336	2677-63-336	2878-66-336				36

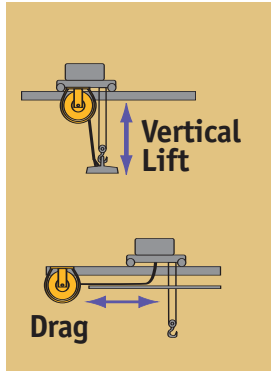

90 ft. 27.45 m	100 ft. 30.5 m	110 ft. 33.55 m	120 ft. 36.6 m	130 ft. 39.65 m	140 ft. 42.7 m	150 ft. 45.75 m	No. of Cond.
1143-16-303	1164-16-303	1164-05-303	1164-05-303	1255-05-303	1255-05-303	1255-17-303	3
1143-16-304	1164-05-304	1164-05-304	1255-05-304	1255-17-304	1255-17-304	2056-53-304	4
1164-17-306	1356-16-306	2056-55-306	2056-56-306	2058-60-306	2058-60-306	2059-60-306	6
1356-16-308	2056-56-308	2057-60-308	2347-60-308	2347-60-308	2349-63-308	2349-63-308	8

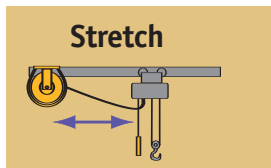

140 ft. 42.7 m	160 ft. 48.8 m	180 ft. 54.9 m	200 ft. 61 m	240 ft. 73.2 m	280 ft. 85.4 m	320 ft. 97.6 m	No. of Cond.
1164-10-303	1255-10-303	1255-10-303	1255-10-303				3
1164-10-304	1255-10-304	1255-10-304	1255-10-304				4
1255-10-306	1443-10-306						6
1443-10-308	1443-10-308						8
1443-10-310	1445-10-310						10
1443-10-312	1445-10-312						12
1475-05-316	1475-05-316						16
1475-05-320	2576-50-320						20
2576-50-324	2576-50-324						24
2576-55-330	2770-60-330						30
2779-60-336	2770-60-336						36

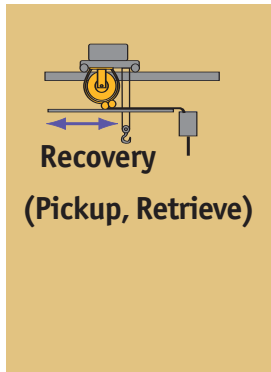

DIMENSIONS

SERIES	0900	1000M	1100M	1200M	1300M	1400M	1500M	2000	2300	2400	2500	2600	2700	2800
PAGE NO.	38	38	39	40	40	41	41	42	43-44	45	46	46	47	47

If cable reel is not found in selection charts, please consult factory.

No. 12 Cable

Cable rated at 600 volts

ALL MODELS ARE LESS CABLE

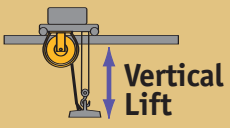
Application	Number of Conductors	Length of Active Cable (feet, meters)							
		20 ft. 6.1 m	30 ft. 9.15 m	40 ft. 12.2 m	50 ft. 15.25 m	60 ft. 18.3 m	70 ft. 21.35 m	80 ft. 24.4 m	
 <p>Vertical Lift</p>	3	0951-05-203	0951-05-203	0951-05-203	0951-04-203	1051-01-303	1051-01-303	1143-10-303	
	4	0951-05-204	0951-05-204	0951-04-204	1051-01-304	1051-01-304	1142-10-304	1143-16-304	
	6	0951-05-206	0951-04-206	1051-02-306	1051-02-306	1051-02-306	1143-16-306	1163-05-306	
	8	0951-05-208	1051-02-308	1051-02-308	1051-02-308	1164-05-308	1253-05-308	1253-17-308	
	10	1051-01-310	1051-02-310	1142-16-310	1253-05-310	1253-05-310	1253-17-310	1544-16-310	
	12	1051-01-312	1051-02-312	1142-16-312	1253-05-312	1253-17-312	1354-16-312	1544-16-312	
	16	1142-10-316	1142-16-316	1163-05-316	1253-17-316	1354-16-316	1546-05-316	1546-05-316	
	20	1142-16-320	1163-05-320	1253-17-320	1544-16-320	1544-05-320	1546-05-320	2346-63-320	
	24	1163-16-324	1253-17-324	1544-16-324	1544-05-324	1576-17-324	2378-65-324	2378-70-324	
	30	1163-05-330	1354-16-330	1544-05-330	1544-17-330	2375-65-330	2377-70-330	2379-76-330	

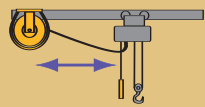
Application	No. of Cond.	Length of Active Cable (feet, meters)							
		20 ft. 6.1 m	30 ft. 9.15 m	40 ft. 12.2 m	50 ft. 15.25 m	60 ft. 18.3 m	70 ft. 21.35 m	80 ft. 24.4 m	
 <p>Stretch</p>	3	0951-05-203	0951-04-203	0951-08-203	1051-02-303	1051-02-303	1051-02-303	1143-05-303	
	4	0951-05-204	0951-04-204	0951-08-204	1051-02-304	1051-02-304	1143-05-304	1143-05-304	
	6	0951-04-206	0951-08-206	1051-02-306	1051-03-306	1143-05-306	1143-17-306	1164-17-306	
	8	0951-08-208	1051-02-308	1051-03-308	1143-05-308	1164-17-308	1354-16-308	1356-05-308	

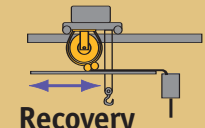
Application	No. of Cond.	Length of Active Cable (feet, meters)							
		50 ft. 15.2 m	60 ft. 18.3 m	70 ft. 21.35 m	80 ft. 24.4 m	90 ft. 27.45 m	100 ft. 30.5 m	120 ft. 36.6 m	
 <p>Recovery (Pickup, Retrieve)</p>	3	0951-04-203	1051-01-303	1051-01-303	1051-01-303	1143-10-303	1143-10-303	1163-10-303	
	4	1051-01-304	1051-01-304	1051-01-304	1143-10-304	1143-10-304	1143-10-304	1164-10-304	
	6	1051-01-306	1051-01-306	1143-10-306	1163-10-306	1164-10-306	1253-10-306	1253-10-306	
	8	1051-01-308	1164-10-308	1253-10-308	1253-10-308	1253-10-308	1253-10-308	1443-10-308	
	10	1253-10-310	1253-10-310	1253-10-310	1443-10-310	1443-10-310	1443-10-310	1475-10-310	
	12	1253-10-312	1253-10-312	1443-05-312	1443-05-312	1443-05-312	1443-05-312	1475-05-312	
	16	1253-10-316	1253-10-316	1443-05-316	1443-05-316	1445-05-316	1475-05-316	1475-05-316	
	20	1443-05-320	1443-05-320	1443-05-320	1445-05-320	1145-05-320	1475-05-320	1475-05-320	
	24	1445-05-324	1475-05-324	1475-05-324	1475-05-324	1476-05-324	2577-60-324	2578-60-324	
	30	1544-05-330	1576-05-330	1576-05-330	1576-05-330	2377-60-330	2577-60-330	2578-60-330	

APPLICATION NOTES

See page 12 for application details.

Vertical Lift Loads in addition to cable weight are not included. Lift reels will also drag cables over supporting surface, or stretch cables with 10% sag.

Horizontal Stretch (unsupported) Maximum sag is 6% of total cable length. If 10% sag can be allowed, use LIFT chart.

Recovery (Pickup, Retrieve) Reel is mounted on moving equipment. Pay-out and recovery can be two-way with power source at midpoint. Typical mounting is 3 ft. from surface to lower reel flange. Speeds to 200 fpm. For other conditions, contact factory. **If slow moving recovery application (50fpm or less) more tension may be required. Please contact factory for application assistance.**

When ordering, specify cable size and type. Maximum operating speed: 200 fpm.; for other conditions, consult factory. Ratchet lock standard on Series 0900 and 1000M reels. Optional ratchet lock available on Series 1100M through 1400M; Specify by adding "-L" to model number. Junction box data, see page 38; junction boxes are required to comply with CSA specifications. Cable grips are recommended for all applications. See page 37.

	90 ft. 27.45 m	100 ft. 30.5 m	120 ft. 36.6 m	140 ft. 42.7 m	160 ft. 48.8 m	180 ft. 54.9 m	200 ft. 61 m	No. of Cond.
1143-16-303	1164-16-303	1164-05-303	1255-05-303	1255-05-303	2058-53-303	2058-53-303		3
1143-16-304	1164-16-304	1164-05-304	1255-17-304	2056-53-304	2057-53-304	2058-55-304		4
1164-05-306	1255-05-306	1356-16-306	2057-55-306	2347-56-306	2340-60-306	2340-60-306		6
1255-17-308	1356-16-308	1546-16-308	2346-56-308	2348-60-308	2370-63-308	2476-53-308		8
1544-16-310	2345-56-310	2377-60-310	2379-63-310	2370-65-310	2477-55-310	2478-56-310		10
1546-05-312	2346-60-312	2378-62-312	2379-65-312	2476-55-312	2477-56-312	2479-60-312		12
2347-63-316	2377-63-316	2370-70-316	2476-56-316	2478-60-316	2670-63-316	2670-63-316		16
2347-65-320	2379-70-320	2476-56-320	2677-60-320	2679-63-320	2870-65-320	2870-66-320		20
2370-76-324	2570-76-324	2677-63-324	2878-65-324	2870-70-324				24
2370-76-330	2676-60-330	2678-65-330	2870-70-330					30

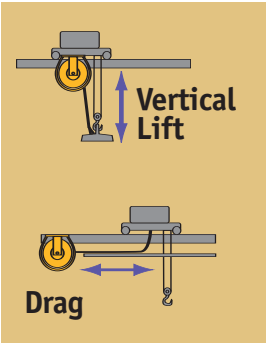

	90 ft. 27.45 m	100 ft. 30.5 m	110 ft. 33.55 m	120 ft. 36.6 m	130 ft. 39.65 m	140 ft. 42.7 m	150 ft. 45.75 m	No. of Cond.
1164-05-303	1164-05-303	1255-17-303	1255-17-303	2056-53-303	2056-53-303	2057-55-303		3
1164-05-304	1164-17-304	1255-17-304	2056-55-304	2056-55-304	2057-56-304	2058-60-304		4
1356-16-306	1356-16-306	2056-56-306	2058-60-306	2058-60-306	2050-63-306	2340-63-306		6
1356-05-308	2057-60-308	2348-63-308	2348-63-308	2340-66-308	2340-66-308	2446-55-308		8

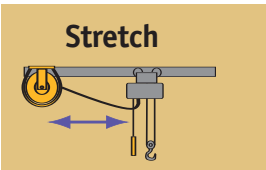

	140 ft. 42.7 m	160 ft. 48.8 m	180 ft. 54.9 m	200 ft. 61 m	240 ft. 73.2 m	280 ft. 85.4 m	320 ft. 97.6 m	No. of Cond.
1255-10-303	1255-10-303	1255-10-303	1255-10-303					3
1255-10-304	1255-10-304	1255-10-304	1255-10-304					4
1255-10-306	1443-10-306							6
1443-10-308	1445-10-308							8
1475-10-310	1475-10-310							10
1475-05-312	1475-05-312							12
1475-05-316	1475-05-316							16
2577-55-320	2577-55-320							20
2779-60-324	2770-60-324							24
2770-60-330	2876-60-330							30



DIMENSIONS

SERIES	0900	1000M	1100M	1200M	1300M	1400M	1500M	2000	2300	2400	2500	2600	2700	2800
PAGE NO.	38	38	39	40	40	41	41	42	43-44	45	46	46	47	47

If cable reel is not found in selection charts, please consult factory.

No. 10 Cable

Cable rated at 600 volts

ALL MODELS ARE LESS CABLE

Application	Number of Conductors	Length of Active Cable (feet, meters)							
		20 ft. 6.1 m	30 ft. 9.15 m	40 ft. 12.2 m	50 ft. 15.25 m	60 ft. 18.3 m	70 ft. 21.35 m	80 ft. 24.4 m	
<p>Vertical Lift</p>	3	0951-05-203	0951-05-203	0951-04-203	1051-01-303	1051-02-303	1051-02-303	1143-16-303	
	4	0951-05-204	0951-04-204	1051-01-304	1051-02-304	1051-02-304	1051-02-304	1143-16-304	
	6	0951-06-206	0951-08-206	1051-02-306	1051-02-306	1143-05-306	1163-05-306	1164-17-306	
	8	1051-01-308	1051-02-308	1142-16-308	1253-05-308	1253-17-308	1354-16-308	1544-16-308	
	10	1142-10-310	1142-16-310	1163-05-310	1253-17-310	1354-16-310	1544-16-310	1544-05-310	
	12	1142-10-312	1142-16-312	1163-05-312	1253-17-312	1354-16-312	1544-05-312	1546-05-312	
	16	1142-16-316	1163-05-316	1354-16-316	1544-05-316	1544-05-316	1546-17-316	2346-65-316	
	20	1163-05-320	1253-17-320	1544-05-320	1544-05-320	2375-65-320	2376-66-320	2379-76-320	
	24	1253-05-324	2053-53-324	1544-05-324	1574-17-324	2376-65-324	2378-76-324	2370-80-324	

Application	No. of Cond.	Length of Active Cable (feet, meters)							
		20 ft. 6.1 m	30 ft. 9.15 m	40 ft. 12.2 m	50 ft. 15.25 m	60 ft. 18.3 m	70 ft. 21.35 m	80 ft. 24.4 m	
<p>Stretch</p>	3	0951-05-203	0951-08-203	0951-08-203	1051-02-303	1143-16-303	1143-05-303	1143-05-303	
	4	0951-04-204	0951-08-204	1051-02-304	1051-03-304	1143-05-304	1143-05-304	1143-17-304	
	6	0951-08-206	1051-02-306	1051-03-306	1143-05-306	1143-17-306	1354-16-306	1356-05-306	
	8	1051-02-308	1051-03-308	1142-17-308	1354-16-308	1354-05-308	1356-05-308	1546-17-308	

Application	No. of Cond.	Length of Active Cable (feet, meters)							
		50 ft. 15.2 m	60 ft. 18.3 m	70 ft. 21.35 m	80 ft. 24.4 m	90 ft. 27.45 m	100 ft. 30.5 m	120 ft. 36.6 m	
<p>Recovery (Pickup, Retrieve)</p>	3	1051-01-303	1051-01-303	1051-01-303	1051-01-303	1143-10-303	1163-10-303	1164-10-303	
	4	1051-01-304	1051-01-304	1051-01-304	1143-10-304	1163-10-304	1163-10-304	1253-10-304	
	6	1051-01-306	1142-10-306	1143-10-306	1163-10-306	1253-10-306	1253-10-306	1443-10-306	
	8	1253-10-308	1253-10-308	1253-10-308	1443-05-308	1443-05-308	1443-05-308	1475-05-308	
	10	1253-10-310	1253-10-310	1443-05-310	1443-05-310	1443-05-310	1475-05-310	1475-05-310	
	12	1253-10-312	1253-10-312	1443-05-312	1443-05-312	1443-05-312	1475-05-312	1475-05-312	
	16	1443-05-316	1445-05-316	1445-05-316	1445-05-316	1445-05-316	1475-05-316	1476-05-316	
	20	1544-16-320	1576-16-320	1576-16-320	1576-16-320	1576-16-320	2577-60-320	2578-60-320	
	24	1576-05-324	1576-05-324	1576-05-324	1576-05-324	2577-60-324	2578-60-324	2876-55-324	

APPLICATION NOTES

See page 12 for application details.

Vertical Lift Loads in addition to cable weight are not included. Lift reels will also drag cables over supporting surface, or stretch cables with 10% sag.

Horizontal Stretch (unsupported) Maximum sag is 6% of total cable length. If 10% sag can be allowed, use LIFT chart.

Recovery (Pickup, Retrieve) Reel is mounted on moving equipment. Pay-out and recovery can be two-way with power source at mid-point. Typical mounting is 3 ft. from surface to lower reel flange. Speeds to 200 fpm. For other conditions, contact factory. **If slow moving recovery application (50fpm or less) more tension may be required. Please contact factory for application assistance.**

When ordering, specify cable size and type. Maximum operating speed: 200 fpm.; for other conditions, consult factory. Ratchet lock standard on Series 0900 and 1000M reels. Optional ratchet lock available on Series 1100M through 1400M; Specify by adding “-L” to model number. Junction box data, see page 38; junction boxes are required to comply with CSA specifications. Cable grips are recommended for all applications. See page 37.

90 ft. 27.45 m	100 ft. 30.5 m	120 ft. 36.6 m	140 ft. 42.7 m	160 ft. 48.8 m	180 ft. 54.9 m	200 ft. 61 m	No. of Cond.
1143-16-303	1164-05-303	1164-05-303	1255-17-303	2056-53-303	2058-55-303	2058-55-303	3
1164-05-304	1164-05-304	1255-17-304	2056-53-304	2346-55-304	2347-56-304	2349-60-304	4
1255-17-306	1356-16-306	2346-56-306	2347-60-306	2349-63-306	2370-63-306	2477-53-306	6
1546-05-308	1546-05-308	2378-63-308	2379-65-308	2476-55-308	2477-56-308	2479-60-308	8
1546-05-310	2377-63-310	2378-65-310	2476-55-310	2477-56-310	2479-60-310	2679-60-310	10
2347-63-312	2377-63-312	2370-70-312	2476-56-312	2478-60-312	2670-63-312	2670-63-312	12
2348-70-316	2370-76-316	2477-60-316	2678-63-316	2679-65-316	2870-66-316		16
2370-76-320	2676-60-320	2677-63-320	2879-66-320				20
2676-66-324	2677-63-324	2879-70-324					24

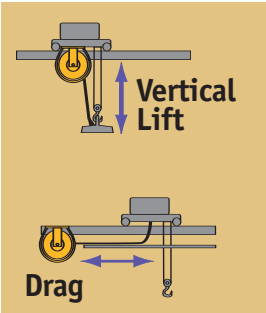

90 ft. 27.45 m	100 ft. 30.5 m	110 ft. 33.55 m	120 ft. 36.6 m	130 ft. 39.65 m	140 ft. 42.7 m	150 ft. 45.75 m	No. of Cond.
1164-17-303	1164-17-303	2055-53-303	2056-55-303	2056-55-303	2057-56-303	2059-60-303	3
1356-16-304	1356-16-304	2056-56-304	2058-60-304	2058-60-304	2058-60-304	2349-63-304	4
1356-05-306	2057-60-306	2058-63-306	2348-63-306	2349-66-306	2446-55-306	2446-55-306	6
2347-63-308	2348-66-308	2349-70-308	2476-56-308	2477-60-308	2477-60-308	2478-60-308	8

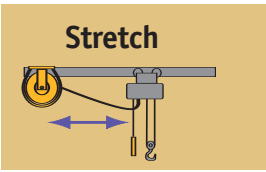

140 ft. 42.7 m	160 ft. 48.8 m	180 ft. 54.9 m	200 ft. 61 m	240 ft. 73.2 m	280 ft. 85.4 m	320 ft. 97.6 m	No. of Cond.
1255-10-303	1255-10-303	1255-10-303	1255-10-303				3
1255-10-304	1443-10-304	1445-10-304	1445-10-304				4
1443-10-306	1445-10-306						6
1475-05-308	1475-05-308						8
1475-05-310	1475-05-310						10
1475-05-312	1475-05-312						12
2577-55-316	2577-55-316						16
2770-60-320	2876-50-320						20
2876-55-324							24

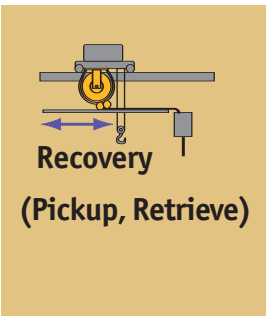

DIMENSIONS

SERIES	0900	1000M	1100M	1200M	1300M	1400M	1500M	2000	2300	2400	2500	2600	2700	2800
PAGE NO.	38	38	39	40	40	41	41	42	43-44	45	46	46	47	47

If cable reel is not found in selection charts, please consult factory.

No. 8 Cable

Cable rated at 600 volts

ALL MODELS ARE LESS CABLE

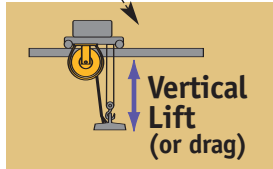
Application	Number of Conductors	Length of Active Cable (feet, meters)							
		20 ft. 6.1 m	30 ft. 9.15 m	40 ft. 12.2 m	50 ft. 15.25 m	60 ft. 18.3 m	70 ft. 21.35 m	80 ft. 24.4 m	
 <p>Vertical Lift (or drag)</p>	2W*	1051-01-402	1051-01-402	1051-01-402	1051-02-402	1143-16-402	1163-16-402	1163-05-402	
	3W	1051-01-403	1051-01-403	1051-02-403	1051-02-403	1163-05-403	1163-05-403	1164-17-403	
	3G	1051-01-404	1051-01-404	1051-02-404	1051-03-404	1163-05-404	1163-05-404	1164-17-404	
	4W	1051-01-404	1051-02-404	1051-03-404	1163-05-404	1253-17-404	1354-16-404	1354-16-404	

*For Magnet Reel applications substitute SR-902 Slip Ring.

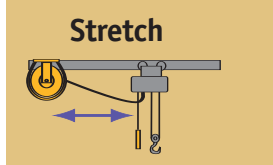
Application	No. of Cond.	Length of Active Cable (feet, meters)							
		20 ft. 6.1 m	30 ft. 9.15 m	40 ft. 12.2 m	50 ft. 15.25 m	60 ft. 18.3 m	70 ft. 21.35 m	80 ft. 24.4 m	
 <p>Stretch</p>	2W	1051-01-402	1051-02-402	1051-02-402	1051-03-402	1143-05-402	1163-17-402	1164-17-402	
	3W	1051-01-403	1051-02-403	1051-03-403	1143-05-403	1163-17-403	1354-16-403	1356-05-403	
	3G	1051-01-404	1051-03-404	1051-03-404	1143-17-404	1354-16-404	1354-16-404	1356-05-404	
	4W	1051-02-404	1051-03-404	1143-17-404	1354-16-404	1354-05-404	1356-05-404	2057-63-404	

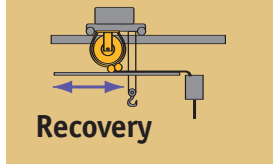
Application	No. of Cond.	Length of Active Cable (feet, meters)							
		50 ft. 15.2 m	60 ft. 18.3 m	70 ft. 21.35 m	80 ft. 24.4 m	90 ft. 27.45 m	100 ft. 30.5 m	120 ft. 36.6 m	
 <p>Recovery</p>	2W	1051-01-402	1142-10-402	1163-10-402	1163-10-402	1253-10-402	1253-10-402	1253-10-402	
	3W	1051-01-403	1163-10-403	1163-10-403	1163-10-403	1253-10-403	1253-10-403	1443-10-403	
	3G	1051-01-404	1163-10-404	1163-10-404	1163-10-404	1253-10-404	1253-10-404	1443-10-404	
	4W	1163-10-404	1253-10-404	1253-10-404	1253-10-404	1253-10-404	1443-05-404	1445-05-404	

APPLICATION NOTES

See page 12 for application details.

Vertical Lift Loads in addition to cable weight are not included. Lift reels will also drag cables over supporting surface, or stretch cables with 10% sag.

Horizontal Stretch (unsupported) Maximum sag is 6% of total cable length. If 10% sag can be allowed, use LIFT chart.

Recovery (Pickup, Retrieve) Reel is mounted on moving equipment.

Pay-out and recovery can be two-way with power source at mid-point. Typical mounting is 3 ft. from surface to lower reel flange. Speeds to 200 fpm. For other conditions, contact factory. **If slow moving recovery application (50fpm or less) more tension may be required. Please contact factory for application assistance.**

When ordering, specify cable size and type. Maximum operating speed: 200 fpm.; for other conditions, consult factory. Ratchet lock standard on Series 0900 and 1000M reels. Optional ratchet lock available on Series 1100M through 1400M; Specify by adding "-L" to model number. Junction box data, see page 38; junction boxes are required to comply with CSA specifications. Cable grips are recommended for all applications. See page 37.

90 ft. 27.45 m	100 ft. 30.5 m	120 ft. 36.6 m	140 ft. 42.7 m	160 ft. 48.8 m	180 ft. 54.9 m	200 ft. 61 m	No. of Cond.
1253-05-402	1255-05-402	2055-53-402	2346-55-402	2347-56-402	2349-60-402	2349-60-402	2W
1255-17-403	1356-16-403	2346-56-403	2347-60-403	2349-63-403	2370-63-403	2477-53-403	3W
1354-16-404	1356-16-404	2346-56-404	2347-60-404	2349-63-404	2476-53-404	2477-55-404	3G
1356-05-404	2346-60-404	2348-63-404	2349-66-404	2476-55-404	2477-56-404	2470-60-404	4W

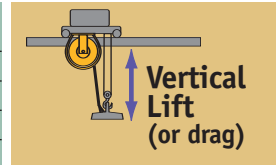

90 ft. 27.45 m	100 ft. 30.5 m	110 ft. 33.55 m	120 ft. 36.6 m	130 ft. 39.65 m	140 ft. 42.7 m	150 ft. 45.75 m	No. of Cond.
1356-16-402	2056-56-402	2056-56-402	2058-60-402	2058-60-402	2349-63-402	2349-63-402	2W
1356-05-403	2057-60-403	2058-63-403	2348-63-403	2349-66-403	2446-55-403	2446-55-403	3W
1356-05-404	2058-63-404	2058-63-404	2349-66-404	2340-70-404	2446-55-404	2446-56-404	3G
2058-66-404	2349-70-404	2340-70-404	2446-56-404	2447-60-404	2447-60-404	2448-60-404	4W

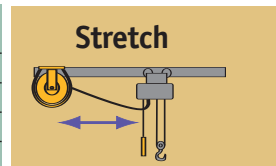

140 ft. 42.7 m	160 ft. 48.8 m	180 ft. 54.9 m	200 ft. 61 m	240 ft. 73.2 m	280 ft. 85.4 m	320 ft. 97.6 m	No. of Cond.
1443-10-402	1445-10-402						2W
1443-10-403	1445-10-403						3W
1445-10-404	1445-10-404						3G
1445-05-404	1475-05-404						4W

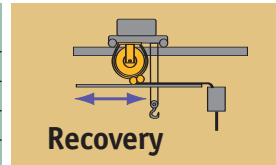

DIMENSIONS

SERIES	0900	1000M	1100M	1200M	1300M	1400M	1500M	2000	2300	2400	2500	2600	2700	2800
PAGE NO.	38	38	39	40	40	41	41	42	43-44	45	46	46	47	47

If cable reel is not found in selection charts, please consult factory.

No. 6 Cable

Cable rated at 600 volts

ALL MODELS ARE LESS CABLE

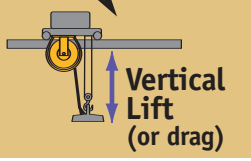
Application	Number of Conductors	Length of Active Cable (feet, meters)						
		20 ft. 6.1 m	30 ft. 9.15 m	40 ft. 12.2 m	50 ft. 15.25 m	60 ft. 18.3 m	70 ft. 21.35 m	80 ft. 24.4 m
	2W*	1051-01-402	1051-02-402	1051-02-402	1051-03-402	1164-05-402	1253-05-402	1253-17-402
	3W	1051-02-403	1051-03-403	1142-05-403	1163-05-403	1253-17-403	1354-16-403	1354-16-403
	3G	1051-02-404	1051-03-404	1142-05-404	1163-17-404	1354-16-404	1354-16-404	1356-05-404
	4W	1051-02-404	1051-03-404	1163-05-404	1253-17-404	1354-16-404	1354-05-404	1546-05-404

*For Magnet Reel applications substitute SR-902 Slip Ring.

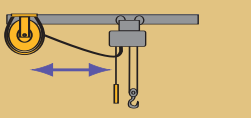
Application	No. of Cond.	Length of Active Cable (feet, meters)						
		20 ft. 6.1 m	30 ft. 9.15 m	40 ft. 12.2 m	50 ft. 15.25 m	60 ft. 18.3 m	70 ft. 21.35 m	80 ft. 24.4 m
	2W	1051-02-402	1051-03-402	1051-03-402	1163-17-402	1354-16-402	1354-16-402	1356-05-402
	3W	1051-02-403	1051-03-403	1143-17-403	1354-16-403	1356-05-403	1356-05-403	2057-63-403
	3G	1051-03-404	1142-05-404	1354-16-404	1354-05-404	1356-05-404	1356-17-404	2058-66-404
	4W	1051-03-404	1142-17-404	1354-16-404	1354-05-404	1356-17-404	2057-66-404	2348-70-404

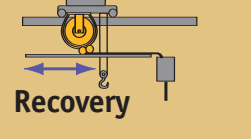
Application	No. of Cond.	Length of Active Cable (feet, meters)						
		50 ft. 15.2 m	60 ft. 18.3 m	70 ft. 21.35 m	80 ft. 24.4 m	90 ft. 27.45 m	100 ft. 30.5 m	120 ft. 36.6 m
	2W	1051-01-402	1164-10-402	1253-10-402	1253-10-402	1253-10-402	1253-10-402	1443-10-402
	3W	1163-10-403	1253-10-403	1253-10-403	1253-10-403	1253-10-403	1445-05-403	1445-05-403
	3G	1163-10-404	1253-10-404	1253-10-404	1253-10-404	1253-10-404	1445-05-404	1445-05-404
	4W	1253-10-404	1253-10-404	1253-10-404	1443-05-404	1445-05-404	1445-05-404	1475-05-404

No. 4 Cable

Cable rated at 600 volts

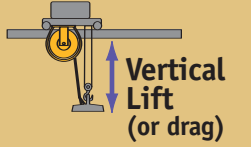
Application	No. of Cond.	Length of Active Cable (feet, meters)						
		20 ft. 6.1 m	30 ft. 9.15 m	40 ft. 12.2 m	50 ft. 15.25 m	60 ft. 18.3 m	70 ft. 21.35 m	80 ft. 24.4 m
	2W*	1051-02-402	1051-03-402	1163-05-402	1253-17-402	1354-16-402	1354-16-402	1544-05-402
	3W	1142-16-403	1163-05-403	1253-17-403	1354-16-403	1354-16-403	1546-05-403	1546-17-403
	3G	1142-16-404	1163-05-404	1354-16-404	1354-16-404	1356-05-404	1546-17-404	2346-65-404
	4W	1142-16-404	1164-17-404	1354-16-404	1544-05-404	1544-17-404	2346-65-404	2347-66-404

*For Magnet Reel applications substitute SR-902 Slip Ring.

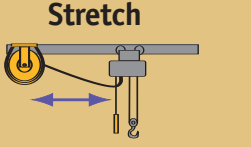
Application	No. of Cond.	Length of Active Cable (feet, meters)						
		20 ft. 6.1 m	30 ft. 9.15 m	40 ft. 12.2 m	50 ft. 15.25 m	60 ft. 18.3 m	70 ft. 21.35 m	80 ft. 24.4 m
	2W	1051-03-402	1142-05-402	1354-16-402	1354-16-402	1356-05-402	1356-17-402	2347-66-402
	3W	1142-05-403	1354-16-403	1354-16-403	1356-17-403	2056-66-403	2347-70-403	2349-76-403
	3G	1142-05-404	1354-16-404	1354-05-404	1356-17-404	2057-70-404	2349-76-404	2340-80-404
	4W	1142-17-404	1354-05-404	1354-17-404	2345-66-404	2348-76-404	2349-76-404	2446-63-404

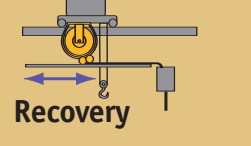
Application	No. of Cond.	Length of Active Cable (feet, meters)						
		50 ft. 15.2 m	60 ft. 18.3 m	70 ft. 21.35 m	80 ft. 24.4 m	90 ft. 27.45 m	100 ft. 30.5 m	120 ft. 36.6 m
	2W	1253-10-402	1253-10-402	1253-10-402	1443-05-402	1445-05-402	1445-05-402	1475-05-402
	3W	1253-05-403	1253-05-403	1445-05-403	1445-05-403	1445-05-403	1475-05-403	1475-05-403
	3G	1253-05-404	1253-05-404	1445-05-404	1445-05-404	1445-05-404	1475-05-404	1476-05-404
	4W	1445-05-404	1445-05-404	1445-05-404	1445-05-404	1476-05-404	1476-05-404	1476-05-404

APPLICATION NOTES

See page 12 for application details.

Vertical Lift Loads in addition to cable weight are not included. Lift reels will also drag cables over supporting surface, or stretch cables with 10% sag.

Horizontal Stretch (unsupported) Maximum sag is 6% of total cable length. If 10% sag can be allowed, use LIFT chart.

Recovery (Pickup, Retrieve) Reel is mounted on moving equipment.

Pay-out and recovery can be two-way with power source at mid-point. Typical mounting is 3 ft. from surface to lower reel flange.

Speeds to 200 fpm. For other conditions, contact factory. **If slow moving recovery application (50fpm or less) more tension may be required. Please contact factory for application assistance.**

When ordering, specify cable size and type. Maximum operating speed: 200 fpm.; for other conditions, consult factory. Ratchet lock standard on Series 0900 and 1000M reels. Optional ratchet lock available on Series 1100M through 1400M; Specify by adding "-L" to model number. Junction box data, see page 38; junction boxes are required to comply with CSA specifications. Cable grips are recommended for all applications. See page 37.

90 ft. 27.45 m	100 ft. 30.5 m	120 ft. 36.6 m	140 ft. 42.7 m	160 ft. 48.8 m	180 ft. 54.9 m	200 ft. 61 m	No. of Cond.
1354-16-402	1356-16-402	2346-56-402	2347-60-402	2349-63-402	2476-53-402	2476-53-402	2W
1356-05-403	1546-05-403	2348-63-403	2349-66-403	2476-55-403	2477-56-403	2470-60-403	3W
1356-05-404	1546-05-404	2348-65-404	2340-70-404	2477-56-404	2479-60-404	2470-60-404	3G
1546-05-404	2347-63-404	2379-66-404	2476-56-404	2478-60-404	2470-62-404		4W

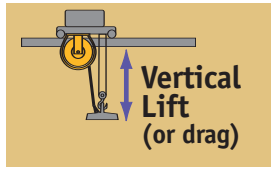

90 ft. 27.45 m	100 ft. 30.5 m	110 ft. 33.55 m	120 ft. 36.6 m	130 ft. 39.65 m	140 ft. 42.7 m	150 ft. 45.75 m	No. of Cond.
1356-05-402	2058-63-402	2348-63-402	2349-66-402	2340-70-402	2446-55-402	2446-56-402	2W
2058-66-403	2349-70-403	2445-56-403	2447-60-403	2447-60-403	2447-60-403	2448-62-403	3W
2059-70-404	2340-76-404	2445-56-404	2447-60-404	2447-60-404	2448-63-404	2449-63-404	3G
2340-76-404	2340-76-404	2476-60-404	2478-63-404	2478-63-404	2479-65-404		4W

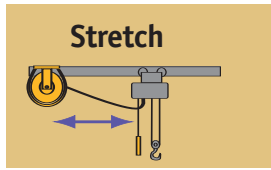

140 ft. 42.7 m	160 ft. 48.8 m	180 ft. 54.9 m	200 ft. 61 m	240 ft. 73.2 m	280 ft. 85.4 m	320 ft. 97.6 m	No. of Cond.
1443-10-402	1445-10-402						2W
1445-05-403	1475-05-403						3W
1445-05-404	1475-05-404						3G
1475-05-404	1475-05-404						4W

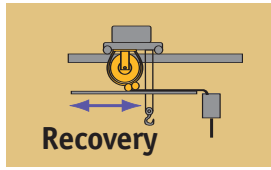

No. 4 Cable

90 ft. 27.45 m	100 ft. 30.5 m	120 ft. 36.6 m	140 ft. 42.7 m	160 ft. 48.8 m	180 ft. 54.9 m	200 ft. 61 m	No. of Cond.
1546-05-402	1546-05-402	2378-65-402	2476-55-402	2477-56-402	2479-60-402		2W
2346-65-403	2379-70-403	2476-56-403	2477-60-403	2679-63-403	2670-65-403		3W
2347-66-404	2379-70-404	2477-60-404	2479-63-404	2670-65-404	2670-65-404		3G
2378-70-404	2370-76-404	2477-60-404	2679-65-404	2670-66-404			4W

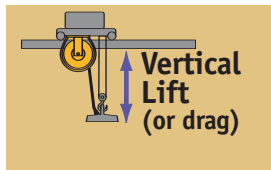

90 ft. 27.45 m	100 ft. 30.5 m	110 ft. 33.55 m	120 ft. 36.6 m	130 ft. 39.65 m	140 ft. 42.7 m	150 ft. 45.75 m	No. of Cond.
2348-70-402	2340-76-402	2476-56-402	2477-60-402	2477-60-402	2479-63-402	2479-63-402	2W
2340-80-403	2477-63-403	2477-63-403	2478-65-403	2470-70-403	2470-70-403		3W
2447-63-404	2477-63-404	2478-65-404	2470-70-404	2470-70-404			3G
2477-63-404	2478-66-404	2470-70-404					4W

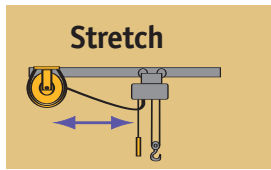

140 ft. 42.7 m	160 ft. 48.8 m	180 ft. 54.9 m	200 ft. 61 m	240 ft. 73.2 m	280 ft. 85.4 m	320 ft. 97.6 m	No. of Cond.
1475-05-402	1475-05-402						2W
1475-05-403	2577-55-403						3W
1476-05-404	2577-55-404						3G
2579-60-404	2579-60-404						4W

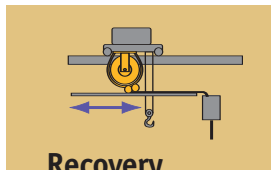

DIMENSIONS

SERIES	0900	1000M	1100M	1200M	1300M	1400M	1500M	2000	2300	2400	2500	2600	2700	2800
PAGE NO.	38	38	39	40	40	41	41	42	43-44	45	46	46	47	47

If cable reel is not found in selection charts, please consult factory.

No. 2 Cable

Cable rated at 600 volts

ALL MODELS ARE LESS CABLE

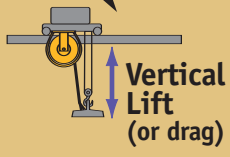
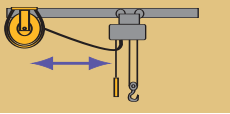
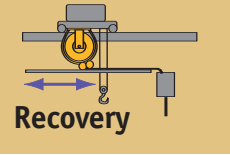
Application	Number of Conductors	Length of Active Cable (feet, meters)						
		20 ft. 6.1 m	30 ft. 9.15 m	40 ft. 12.2 m	50 ft. 15.25 m	60 ft. 18.3 m	70 ft. 21.35 m	80 ft. 24.4 m
 Vertical Lift (or drag)	2W	1142-16-902	1163-05-902	1253-17-902	1544-16-902	1544-05-902	1546-05-902	1546-17-902
	3W	1142-16-903	1164-17-903	1354-16-903	1544-05-903	1544-05-903	2346-65-903	2347-66-903
	3G	1142-05-904	1164-17-904	1354-05-904	1544-05-904	1546-17-904	2346-66-904	2378-70-904
	4W	1163-05-904	1354-16-904	1544-05-904	1544-17-904	2376-66-904	2378-76-904	2379-76-904
 Stretch	No. of Cond.	20 ft. 6.1 m	30 ft. 9.15 m	40 ft. 12.2 m	50 ft. 15.25 m	60 ft. 18.3 m	70 ft. 21.35 m	80 ft. 24.4 m
	2W	1142-05-902	1163-17-902	1354-05-902	1544-17-902	2346-66-902	2347-70-902	2349-76-902
	3W	1142-17-903	1354-05-903	1354-17-903	2345-66-903	2348-76-903	2349-76-903	2446-63-903
	3G	1142-17-904	1354-05-904	2055-66-904	2346-70-904	2348-80-904	2340-85-904	2476-65-904
 Recovery	No. of Cond.	50 ft. 15.2 m	60 ft. 18.3 m	70 ft. 21.35 m	80 ft. 24.4 m	90 ft. 27.45 m	100 ft. 30.5 m	120 ft. 36.6 m
	2W	1443-05-902	1443-05-902	1443-05-902	1445-05-902	1445-05-902	1475-05-902	1475-05-902
	3W	1445-05-903	1445-05-903	1445-05-903	1475-05-903	1476-05-903	1476-05-903	1476-05-903
	3G	1546-05-904	1546-05-904	1546-05-904	1576-05-904	2377-60-904	2377-60-904	2378-60-904
4W	1546-05-904	1576-05-904	1576-05-904	1576-05-904	2377-60-904	2378-60-904	2579-60-904	

No. 1 Cable

Cable rated at 600 volts

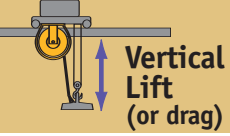
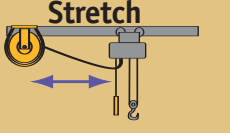
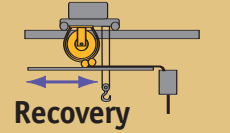
Application	Number of Conductors	Length of Active Cable (feet, meters)						
		20 ft. 6.1 m	30 ft. 9.15 m	40 ft. 12.2 m	50 ft. 15.25 m	60 ft. 18.3 m	70 ft. 21.35 m	80 ft. 24.4 m
 Vertical Lift (or drag)	2W	1163-16-902	1253-17-902	1544-16-902	1544-05-902	1576-17-902	2376-65-902	2378-70-902
	3W	1163-05-903	1354-16-903	1544-05-903	1544-17-903	2376-66-903	2378-76-903	2379-76-903
	3G	1163-17-904	1354-05-904	1544-05-904	2345-65-904	2377-70-904	2378-76-904	2476-63-904
 Stretch	No. of Cond.	20 ft. 6.1 m	30 ft. 9.15 m	40 ft. 12.2 m	50 ft. 15.25 m	60 ft. 18.3 m	70 ft. 21.35 m	80 ft. 24.4 m
	2W	1163-17-902	1354-05-902	1544-17-902	2346-70-902	2378-76-902	2379-80-902	2476-63-902
	3W	1354-16-903	1354-17-903	2345-70-903	2347-76-903	2370-85-903	2476-65-903	2478-70-903
3G	1354-05-904	2054-65-904	2346-76-904	2348-80-904	2476-65-904	2477-70-904	2479-76-904	
 Recovery	No. of Cond.	50 ft. 15.2 m	60 ft. 18.3 m	70 ft. 21.35 m	80 ft. 24.4 m	90 ft. 27.45 m	100 ft. 30.5 m	120 ft. 36.6 m
	2W	1544-16-902	1574-16-902	1576-16-902	1576-16-902	1576-16-902	2577-60-902	2578-60-902
	3W	1546-05-903	1576-05-903	1576-05-903	1576-05-903	2377-60-903	2578-60-903	2579-60-903
3G	1546-05-904	1576-05-904	1576-05-904	2377-60-904	2378-60-904	2579-60-904	2570-60-904	

APPLICATION NOTES

See page 12 for application details.

Vertical Lift Loads in addition to cable weight are not included. Lift reels will also drag cables over supporting surface, or stretch cables with 10% sag.

Horizontal Stretch (unsupported) Maximum sag is 6% of total cable length. If 10% sag can be allowed, use LIFT chart.

Recovery (Pickup, Retrieve) Reel is mounted on moving equipment. Pay-out and recovery can be two-way with power source at mid-point. Typical mounting is 3 ft. from surface to lower reel flange. Speeds to 200 fpm. For other conditions, contact factory. **If slow moving recovery application (50fpm or less) more tension may be required. Please contact factory for application assistance.**

When ordering, specify cable size and type. Maximum operating speed: 200 fpm.; for other conditions, consult factory. Ratchet lock standard on Series 0900 and 1000M reels. Optional ratchet lock available on Series 1100M through 1400M; Specify by adding "-L" to model number. Junction box data, see page 38; junction boxes are required to comply with CSA specifications. Cable grips are recommended for all applications. See page 37.

90 ft. 27.45 m	100 ft. 30.5 m	120 ft. 36.6 m	140 ft. 42.7 m	160 ft. 48.8 m	180 ft. 54.9 m	200 ft. 61 m	No. of Cond.
2347-66-902	2378-66-902	2476-56-902	2677-60-902	2679-63-902	2670-65-902		2W
2378-70-903	2370-76-903	2477-60-903	2679-65-903	2670-66-903			3W
2370-76-904	2476-60-904	2478-63-904	2679-66-904				3G
2370-80-904	2677-63-904	2678-66-904	2870-70-904				4W

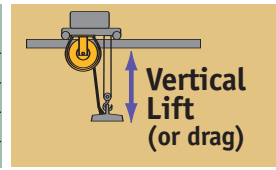

90 ft. 27.45 m	100 ft. 30.5 m	110 ft. 33.55 m	120 ft. 36.6 m	130 ft. 39.65 m	140 ft. 42.7 m	150 ft. 45.75 m	No. of Cond.
2340-80-902	2477-63-902	2477-63-902	2478-65-902	2479-66-902	2670-70-902		2W
2477-63-903	2478-66-903	2470-70-903					3W
2477-66-904	2479-70-904						3G
2478-70-904	2670-76-904						4W

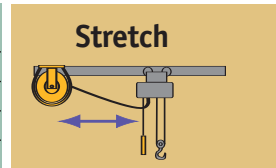

140 ft. 42.7 m	160 ft. 48.8 m	180 ft. 54.9 m	200 ft. 61 m	240 ft. 73.2 m	280 ft. 85.4 m	320 ft. 97.6 m	No. of Cond.
2576-50-902	2576-50-902						2W
2579-60-903	2579-60-903						3W
2579-60-904	2579-60-904						3G
2876-55-904	2877-55-904						4W

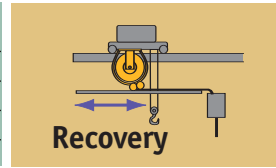

No. 1 Cable

90 ft. 27.45 m	100 ft. 30.5 m	120 ft. 36.6 m	140 ft. 42.7 m	160 ft. 48.8 m	180 ft. 54.9 m	200 ft. 61 m	No. of Cond.
2370-76-902	2570-76-902	2677-63-902	2878-65-902	2870-70-902			2W
2370-80-903	2677-63-903	2678-66-903	2870-70-903				3W
2477-65-904	2677-66-904	2679-70-904					3G

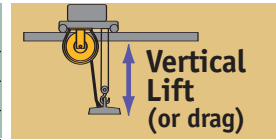

90 ft. 27.45 m	100 ft. 30.5 m	110 ft. 33.55 m	120 ft. 36.6 m	130 ft. 39.65 m	140 ft. 42.7 m	150 ft. 45.75 m	No. of Cond.
2477-65-902	2677-66-902	2679-70-902					2W
2478-70-903	2670-76-903						3W
2470-76-904							3G

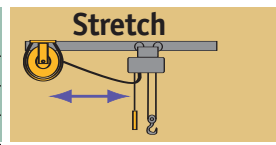

140 ft. 42.7 m	160 ft. 48.8 m	180 ft. 54.9 m	200 ft. 61 m	240 ft. 73.2 m	280 ft. 85.4 m	320 ft. 97.6 m	No. of Cond.
2875-50-902	2875-50-902						2W
2876-55-903	2877-55-903						3W
2877-55-904	2878-55-904						3G

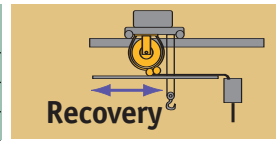

DIMENSIONS

SERIES	0900	1000M	1100M	1200M	1300M	1400M	1500M	2000	2300	2400	2500	2600	2700	2800
PAGE NO.	38	38	39	40	40	41	41	42	43-44	45	46	46	47	47

If cable reel is not found in selection charts, please consult factory.

Mill Duty Service Option

The Mill Duty Service option is available on all reels with external spring drive motors. This includes 2000 through 2800 Series reels.

■ This option is recommended for reels used in critical processes, where downtime must be held to an absolute minimum, or where high labor costs make it necessary to minimize installation time.

■ To order the service option add the suffix **-MD** to the model number of any 2000 through 2800 Series Reel.

■ The features of the Mill Duty Service option are designed to make installation and service of Aero-Motive Cable Reels faster and easier than any other brand available.

Easy Cable Connections

All Mill Duty Reels feature two junction boxes which provide quick, easy access for all working and lead-in cable connections.

The working cable connection is made at a junction box attached to the slip ring chamber. Cable passes through a watertight connector at the junction box.



Self-contained slip ring assembly can be removed in one piece for service and a replacement installed in a matter of minutes.

High temperature lead wires are installed at the factory, connecting the slip ring to the junction box. Working cable can be installed without disturbing the slip ring or removing the slip ring cover.

Power supply "lead-in" is made at a junction box (up to 2" NPT hole size for conduit). Internal wiring is provided by high temperature leads from the slip ring through the stationary mainshaft to the junction box.

- Service option available on all Series 2000 - 2800 models
- Use option when downtime is critical
- Two junction boxes provide quick access for all working and lead-in cable connections
- Quick change spring motor is standard on all Series 2000 - 2800
- To order, add suffix "-MD" to model number on any Series 2000 - 2800
- A full line of Mill Duty Reels is available. Just ask your representative for the Mill Duty Catalog.



Fast Tensioning End Plate

The fast-tensioning end plate is designed so that set-up and tensioning of a reel can be

completed in a matter of seconds, reducing critical downtime. Tension is set after the cable has been installed and final electrical connections are made. No special tools are required to set tension. This is done using a bar or wrench rotating an external nut clockwise, as one 360° turn of the nut puts one setup turn on the spring. A second external nut is used for decreasing the tension.

Quick Change Spring Motor

A quick-change spring motor is provided on all 2000 through 2800 Series Cable Reels. A drive pin engages the motor shaft with the drive shaft allowing the spring motor change to be completed in moments, reducing critical downtime. Resetting the tension is done without unhooking the cable, with the fast-tension end plate on the spring motor. All spring motors are lubricated for life and are inter-



changeable between reels within the 2000 through 2800 group. ONE size spring is used in ALL spring motors to reduce the number of replacement parts maintained for critical applications.

Reels for Hazardous Locations

All series 1100M-2800 reels are available with enclosures which are designed to comply with requirements for the following locations as defined by the National Electric Code:

- Class I, Division I, Group C and D
- Dust-ignition proof for Class II, Division I, Group E, F and G
- Suitable for Class III, Division I, Outdoor Hazardous locations

Fully enclosed junction boxes have connecting leads which are sealed at both ends with a sealing compound. Slip rings are oversized, and constructed of extra heavy material.

These Pow-R-Matic Reels (Models 1100M through 2800) are available with 3 to 10 conductors (35 Amp slip rings). Nos. 18 to 10 AWG; or 3 or 4 conductors (75 Amp. slip rings), Nos. 8 to 4 AWG.

TO ORDER: add suffix "-X" to catalog number to designate the above construction.

Note: Ground wire is connected through slip ring and to frame of reel on ALL models.



- Available on all Series 1100 - 2800 models
- Class I, Division I, Group C & D
- Dust-ignition proof for Class II, Division I, Group E, F, and G
- Suitable for Class III, Division I, Outdoor Hazardous locations
- Fully enclosed junction boxes with connecting leads
- Oversized, rugged construction slip rings
- To order, add suffix "-X" to model number on any Series 1100 - 2800

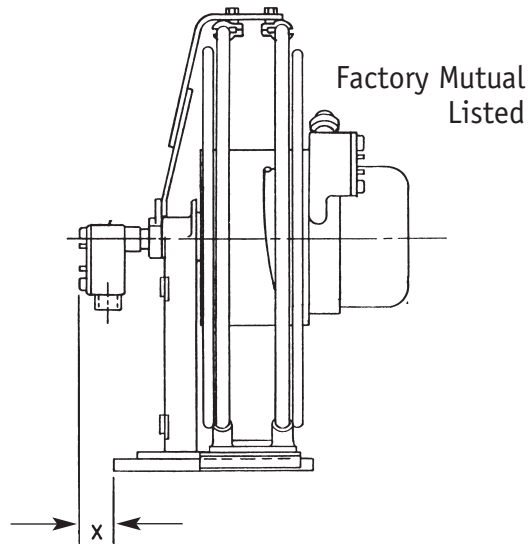

Junction box included on Hazardous Location models. Line entrance tapped as required by the National Electric Code.

On Series 1100M-1500M, the junction box will increase the width of the reel as follows:

Reel Series	X Dimension	
	in.	mm
1100M	6.25	158.8
1200M	4.13	104.9
1300M	4.13	104.9
1400M	4.13	104.9
1500M	4.13	104.9

The junction box does not affect width on Series 2000-2800.

*NOTE: The slip ring cover on hazardous location reels will extend .50 inch (12.7mm) farther than on standard models.

If dimensions are critical, consult factory for certified prints.

Welding Reels

Aero-Motive's Electric Welding Reels are built to high quality standards. Standard models cover the four most desirable wire sizes.

- Containerized mainspring for safe and easy handling
- Weathertight design
- Safety declutching drive hub
- Rugged four-roller guide on 4000 & 5000 series
- Adjustable guide arm on 4000 & 5000 series
- Permanent lubrication
- Ratchet lock



4 0 0 0 SERIES WELDING REELS

Dimensions similar to Series 0900 (Page 38)

Catalog No.	AWG Wire Size.	Cable Length (ft)	Amp Rating
ERA4000	Less Cable	—	375*
ERA4450	4	50	145
ERA4250	2	50	250
ERA4150	1	50	250
ERA4040	1/0	40	350
ERA4940	2/0	40	375

Cable included on all models except ERA4000.

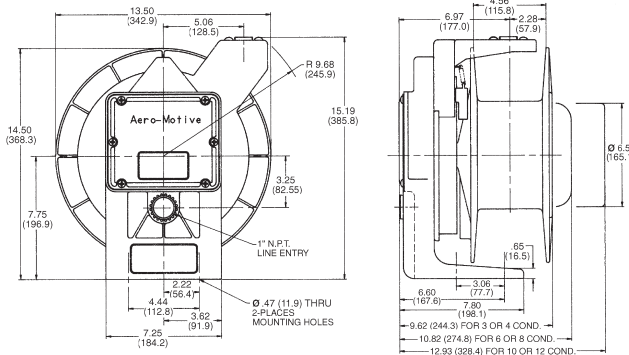

5 0 0 0 SERIES WELDING REELS

Dimensions similar to Series 1000M (Page 38)

Catalog No.	AWG Wire Size.	Cable Length (ft)	Amp Rating
ERL51000	Less Cable	—	375*
ERL51280	2	80	150
ERL51180	1	80	200
ERL51075	1/0	75	250
ERL51960	2/0	60	300

Cable included on all models except ERL51000.

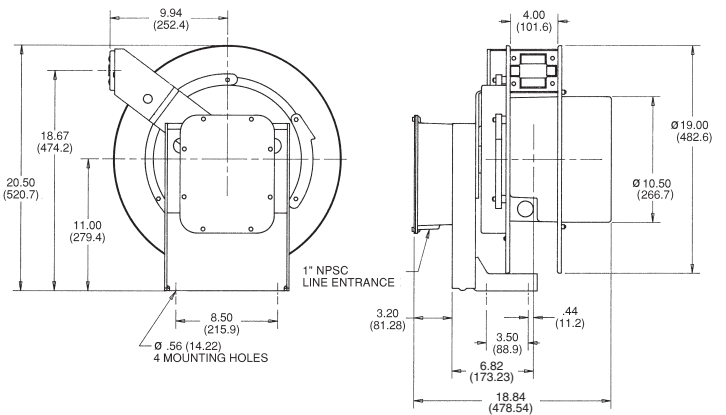

6 0 0 0 SERIES WELDING REELS

■ Dimensions similar to Series 1100M (Page 39)

Catalog No.	AWG Wire Size.	Cable Length (ft)	Amp Rating
ERM60000	Less Cable	—	450*
ERM61100	1	100	150
ERM60110	1/0	110	200
ERM69090	2/0	90	250

Cable included on all models except ERM60000.

When cable is installed, lengths shown in selection charts are maximum allowed when used with corresponding wire size.

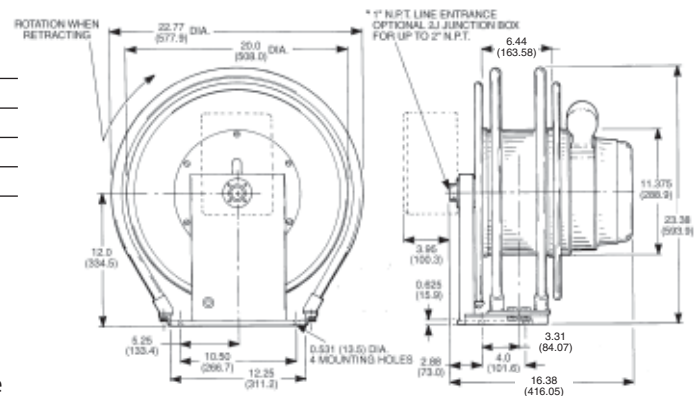

*Rating is established for slip ring only. The proper wire size must be used to obtain this rating.

Pendent Station Retractors

Spring powered retractors provide a simple, inexpensive means of lifting pendent stations, connectors, lights, and more out of the way when not in use. A simple tug on the cable returns the pendent to its original position.

To select a retractor, add the total weight of the pendent, the cable between the pendent and the cable clamp, and half the cable hanging in the loop. Select a retractor that has sufficient weight capacity and travel distance to fit your requirements.

R F L 4-8 LB. RETRACTOR

- Easy tension adjustment without tools
- Full range of motion with 360° swivel hanger
- Nylon-covered steel cable
- Ratchet lock

Model	Weight		Cable Travel	
	lbs.	kg	ft.	m
RFL6	4-6	1.8-2.7	6.6	2
RFL8	6-8	2.7-3.6	6.6	2

B F L 6-24 LB. BALANCERS

- Heavy duty, containerized spring
- Full range of motion with 360° swivel hanger
- High-impact composite housing
- Ratchet lock
- Shackle design for secure mounting

Model	Weight		Cable Travel	
	lbs.	kg	ft.	m
BFL6	3-6	1.4-2.7	6.6	2
BFL9	6-9	2.7-4.1	6.6	2
BFL13	9-13	4.1-5.9	6.6	2
BFL18	13-18	5.9-8.2	6.6	2
BFL24	18-24	8.2-10.9	6.6	2



1 5 1 5 1-30 LB. TORQUE REELS

- Easy external tension adjustment
- Series T offers automatic drum lock

Model	Weight		Active Travel		Tension Build Up	
	lb.	kg	ft.	m	lb.	kg
0515T	5	2.3	15	4.58		
1015T	10	4.5	15	4.58		
1515T	15	6.8	15	4.58	19	8.64



Secondary Support Cable

A secondary support cable or chain should be attached to equipment mounted overhead to ensure against injury in the event of a failure of the hanger or supporting structure.

Hose and Cable Support

Model	Cable/Hose Dia.
61020	0.49"-0.91"
61021	0.91"-1.25"



Balancer Secondary Support Chains

Model	Description	Max. Length
H13760001	Support for RFL	20"
H13760000	Support for BF	20"

Static Discharge Grounding Reels

Eliminates static build-up. Spring-operated, automatic retrieve reels.

The 2050-Y Reel with a "Y" bridle allows two ground connections at the same time, providing maximum efficiency.



2050 STATIC DISCHARGE REELS

- Spring operated, automatic retrieve reel
- Stranded steel aircraft cable is 3/32".
- Provides light, constant spring tension on the cable
- 100 ampere ground clamp
- Rubber cable stop

Catalog no.	Cable length		Net weight		Resistance ohms
	ft.	m	lbs.	Kg	
2050	50	15.24	12	5.44	2.0
2050-Y*	50	15.24	12	5.44	2.0
2050NC	50	15.24	12	5.44	2.0
2050CT	50	15.24	12	5.44	2.0
2050NCCT	50	15.24	12	5.44	2.0

"NC" = nylon coated cable 3/32"

"CT" = constant tension models.

*2050 Reel with "Y" Bridle (30 ft. payout then 20 ft. bridle for each branch, with clamps) allows simultaneous grounding at two points.

Ground Fault Cable Retractor

Models GR900 and GR1000 are sturdy compact spring-powered cable reels that provide a convenient and efficient method of retracting and storing equipment ground cables on electric utility service trucks requiring a minimum of maintenance.

GR GROUND FAULT REELS

- Retracts temporary ground cable for portable equipment
- Ground cable protection when not in use.
- Compact design provides more efficient use of vehicle storage space.
- Easy field cable termination
- No bonding required as ground cable connected directly to collector ring.



Capacity

Cable AWG Model	Length (ft., meters)		
#2	40	12.2	GR900
1/0	40	12.2	GR900
2/0	40	12.2	GR900
2/0	60	18.3	GR1000L
4/0	50	15.2	GR1000L

Qualification Tests

Certified testing 2/0 AWG sample with cable fully extended:

Scenario/Result	Duration	Amplitude	Resistance	
			Before	After
one shot/ rotated freely same resistance after rotating	8 cycles	18.4 kA	0.548m	0.610m
reclose sequence/ rotated freely same resistance after rotating	8 cycles (2 sec)	18.7 kA	0.541m	
resistance after rotating	8 cycles (15 sec)	18.6 kA		
	9 cycles	18.2 kA		0.639m
breaker failure/ rotating freely 0.646m resistance after rotating to failure/ 2.0 cable lead fused open 6 in. from reel. No damage to collector ring.	100 cyc.	15.6 kA	0.594m	0.638m
	101 cyc.	15.5 kA	n/a	

Accessories and Options

Use this selection chart for all standard accessories and options available on Pow-R-Matic Reels.

Accessory	Catalog No	0900	1000M-2000M	1100M	1200M & 1400M	1300M & 1500M	2000	2300	2400	2500-2600-2700-2800
Four-Roller Guide	Incl	Incl	NA	NA	NA	NA	NA	NA	NA	NA
	2FM	NA	NA	Opt	Opt	Opt	Opt	NA	NA	NA
	3FM	NA	NA	Opt	Opt	Opt	Opt	Opt	Opt	Opt*
Junction Box	Incl	Incl	Opt	Opt	Opt	Opt	Opt	Opt	Opt	Opt
Pivot Base (330°)	Opt	Opt	Opt	Opt	Opt	Opt	Opt	Opt	Opt	NA
Guide Arm	Incl	Incl	NA	NA	NA	NA	NA	NA	NA	NA
Guide Rails	NA	NA	Incl	Incl	Incl	Incl	Incl	Incl	Incl	NA
Ratchet Lock (-L)	Incl	Incl	Opt	Opt	NA	NA	NA	NA	NA	NA
Hazardous Locations (-X)	NA	NA	Lim	Lim	Lim	Lim	Lim	Lim	Lim	Lim
Marine Service	NA	NA	Spcl	Spcl	Spcl	Spcl	Spcl	Spcl	Spcl	Spcl
Silver Ring/Brush	Opt	Opt	Opt	Opt	Opt	Opt	Opt	Opt	Opt	Opt
Service Package (-MD)	NA	NA	NA	NA	NA	Opt	Opt	Opt	Opt	Opt

KEY: Opt = Optional
 Incl = Included
 Spcl = Special - Consult factory for current availability of specials.
 Cable Grips, see below
 NA = Not Available
 Lim = Limited
 *Must be mounted separately
 **Not normally used

Four-Roller Guide

A four-roller guide is standard on Series 0900 and 1000M reels. 2FMYE guide is used for cable up to 1.5 in./38.1 mm in diameter. 3FMYE guide is used for cable up to 2.0 in./50.8 mm in diameter. See page 34 for details.

Junction Box

Included as part of reel stand on Series 0900 and 1000M reels. 2JM junction box has up to 2" NPT. See page 35 for further details.

Pivot Base

Allows for 330° pivot. See page 34 for details. Always give complete model number of reel when ordering pivot base.

Marine Service

No exposed aluminum parts, Powder paint, all exposed fasteners up to 5/8" stainless steel. Special order.

Hazardous Locations

See page 29 for details

Silver Plated Rings and Silver Brush Contacts

Available on 30 and 35 ampere slip rings only.

Service Package

Includes external fast tension end plate, 2-J Junction Box for input connection, and second junction box for easy connection of working cable without opening slip ring housing and disturbing brush-holder and brush alignment. Internal lead wires are also supplied. See page 28.

Ordering

To order a reel with the Ratchet Lock, Hazardous Locations, or Service Package options, add the proper suffix **-L**, **-X**, or **-MD** to the model number. To order any other accessory, order it by name. Example: 2053-50-902, complete with number 3FMYE cable guide.

Cable Grips & Stops

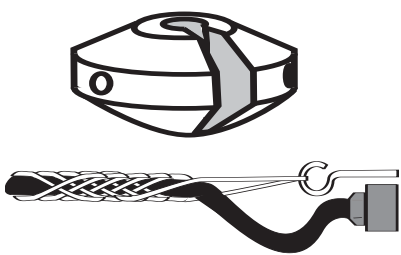

Cable Size OD, ins.	Cable Grip Model	Cable Stop Model
0.30-0.41	37121-11	ST1
0.41-0.56	37121-12	ST1
0.57-0.70	37121-16	ST1
0.70-0.75	37121-18	ST1
0.75-0.82	37121-18	ST2
0.82-0.875	37121-20	ST2
0.875-1.00	37121-20	ST3
1.06-1.25	37121-22	ST3

Cable Guides

Four-roller cable guides are standard on Series 0900 and 1000M. Series 1100M through 2400 reels are equipped with guide rails only. Roller guides are optional on these reels and mount on the guide rails. Ratchet locks are optional on models 1100M through 1400M, and must be ordered with the reel (indicate with “-L” added to model number). NOTE: Roller guides are to be used only to assist in guiding cable onto the reel, and are NOT to be used as a sheave to change direction of payout.

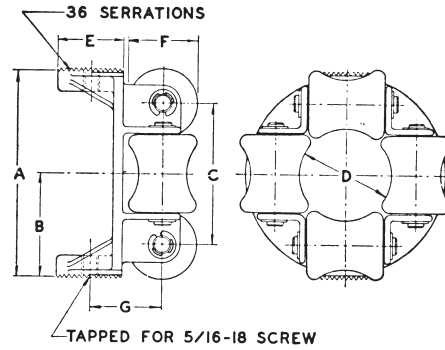

FOUR-ROLLER CABLE GUIDES

2FMYE: For cables up to 1.5"/38.1 mm diameter

3FMYE: For cables up to 2"/50.8 mm diameter (Series 1100M, 2400)

CABLE GUIDE DIMENSIONS

Model	Type of Cable Guide	Maximum Recommended Cable Dia..	Dim.A in. mm	Dim.B in. mm	Dim.C in. mm	Dim.D in. mm	Dim.E in. mm	Dim.F in. mm	Dim.G in. mm
2FMYE	Cable Guide	1.5	4	2	2.69	1.75	1.25	1.31	1.38
2FMYE7*	Cable Guide	38.1	101.6	50.8	68.3	44.5	31.8	33.8	35.1
3FMYE	Cable Guide	2	4	2	3.88	2.63	1.69	1.25	1.81
3FMYE7*	Cable Guide	50.8	101.6	50.8	98.5	66.8	42.9	31.8	46
1R	Guide Rails	—	—	11.72 298	12 305	21 533.4	—	—	—
2R	Guide Rails	—	—	14.19 360	14.25 362	25 635	—	—	—
3R	Guide Rails	—	—	18.19 462	18.25 464	33 838.2	—	—	—

* 2FMYE7 and 3FMYE7 are for 237X and 247X model cable reels

Pivot Bases

ROTATION OF 330° OR LESS (NO COLLECTOR RINGS)
Pivot base allows reel to payout cable in any direction up to 330° where a complete continuous circle is not required.

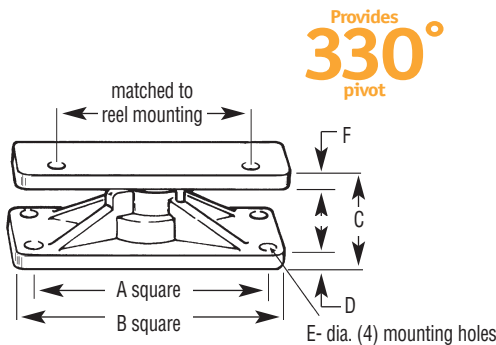

PB SERIES PIVOT BASE

- Allows cable and cord reels to rotate 330°
- Heavy duty ball bearing models

Reel Series	Model	Dim.A in. mm	Dim.B in. mm	Dim.C in. mm	Dim.D in. mm	Dim.E in. mm	Dim.F in. mm
0951, 200,300, 400	PB2A	3 76	4 102	1.44 36.6	0.50 13	0.438 11.13	0.25 6.4
R150	PB10YE	3 76	4 102	2.69 68.3	0.50 13	0.438 11.13	1.25 31.8
1051 5000	PBM7A	10 254	11.5 292	3.76 95.5	0.75 19.1	0.531 13.49	0.63 15.9
1120	PBM3A	10 254	11.5 292	3.76 95.5	0.75 19.1	0.531 13.49	0.63 15.9
1140	PBM3B	10 254	11.5 292	3.76 95.5	0.75 19.1	0.531 13.49	0.63 15.9
1160	PBM3C	10 254	11.5 292	3.76 95.5	0.75 19.1	0.531 13.49	0.63 15.9
1200M 1300M	PBM4A	10 254	11.5 292	3.76 95.5	0.75 19.1	0.531 13.49	0.63 15.9
1440 1540	PBM5A	10 254	11.5 292	3.76 95.5	0.75 19.1	0.531 13.49	0.63 15.9
1470 1570	PBM5B	10 254	11.5 292	3.76 95.5	0.75 19.1	0.531 13.49	0.63 15.9
2000	PB6AX	12 305	14 356	5.79 147	0.63 16	0.563 14.3	0.188 4.7
2300	PB6BX	12 305	14 356	5.79 147	0.63 16	0.563 14.3	0.188 4.7
2400	PB6XX	12 305	14 356	5.79 147	0.63 16	0.563 14.3	0.188 4.7

*Specify reel model when ordering

HEAVY DUTY BALL BEARING MODELS

NOTE: A four-roller guide is required when a pivot base is used. Cable grips are recommended also. See page 33 & 34

Important Cable Selection Data

An important point to remember is that the sole function of Pow-R-Matic Cable Reel is to handle a given cable in a predetermined, specific manner. This re-emphasizes the importance of selecting the right cable for the job it is intended to do.

Important Factors in Cable Selection

■ **Electrical** - Cable must be capable of handling the full operating load of all equipment which can be operated concurrently (total connected horsepower). See horsepower conversion chart on the following page and the chart below for intermittent service ratings.

■ **Mechanical** - Cable must be flexible, portable, and generally neoprene jacketed. Individual conductor stranding should not be less than the number of strands per conductor as listed in the table at left.

■ **Special cables** - Pow-R-Matic Cable Reels can be used with special cables such as stainless steel braided, silicone, or refrasil insulated, etc. Consult the factory for recommended reels for use with cables designed for use in extremely hot or cold temperatures.

Size (AWG)	Minimum Stranding
18	16 strands of #30
16	26 strands of #30
14	41 strands of #30
12	65 strands of #30
10	104 strands of #30
8 through 4	133 strands of #30
2 through 2/0	259 strands of #30*
3/0 through 4/0	427 strands of #30*

*Recommended minimum stranding for best performance and long cable life. If coarser stranding must be used, we suggest you advise the factory so allowance can be made.

Slip Ring Ratings

Ratings refer to the Pow-R-Matic Cable Reel Slip Ring only and may be referred to where cable is being derated for short time (intermittent) service. Ratings are based on two conductor assemblies and must be derated for multiconductor service. Ratings are established for slip rings only, operating in approved enclosures. The proper wire size must be used to obtain these ratings. Consult the factory for specific requirements not covered here.

The first number of the last three digits indicates Slip Ring rating.

Example: 2053-50-902 (9 is the Slip Ring rating). See chart above.

Catalog No.		Ampere Rating		Maximum Operating Temperature
Code	Name-plate	Maximum Load (30 minutes)*	Continuous Duty Cycle	
2	30	30	30	248° F, 120° C
3	35	50	35	248° F, 120° C
4	75	100	75	248° F, 120° C
9	200	250	200	392° F, 200° C

*Maximum running time at full load per hour

Junction Boxes (Weathertight)

Junction boxes are used to connect conduit leading from the power source to the internal wiring of the reel, especially when the lead-in conduit is larger than the threaded connection provided on the reel. The NPT line entrance of the junction box provided with the reel will be equal to or greater than National Electric Code requirements. The chart below lists the junction box line entrance with the proper slip ring designation for reel series 1100M and larger. (See page 38 for NPT size on series 0900 and 1000M). Unless otherwise specified, junction boxes will be threaded to match the chart. In Canada, a junction box is required on all reels to meet CSA approval. Slip Ring designation of model number (last three digits) determine the entrance (NPT) of junction box.

Example: 2053-50-902 (902 is the Slip Ring designation)



Junction boxes should be used when lead-in conduit is larger than threaded connection provided on the reel.

To order, specify 2J-A, 2J-B, 2J-C, or 2J-D. See page 33 for more information.

Model No.	N.P.T.	Slip Ring Designation	Line Entrance NPT	Slip Ring Designation	Line Entrance NPT	Slip Ring Designation	Line Entrance NPT
2J-A	1"	303	1"	316	1½"	403	1"
2J-B	1¼"	304	1"	320	2"	404	1"
2J-C	1½"	306	1"	324	2"	406	1½"
2J-D	2"	308	1¼"	330	2"	902	1½"
		310	1¼"	336	2"	903	1½"
		312	1¼"	402	1"	904	2"

Selecting the Proper Cable

Due to the great variety of electrical applications, types (and manufacturers) of controls, and available currents, it is impossible for the reel manufacturer to select electrical cable for any specific requirement. Because the user, or specifying engineers, are closest to all details involved in any particular requirement, the responsibility for selecting cable must be left in their hands. To assist in the selection of cable, the charts shown on this page and the following procedure are offered as a guide.

For more complete data or specific details, please refer to the National Electric Code.

To select cable:

- Determine motor horsepower. (HP)
- Using Chart A for alternating current (AC) or Chart B for Direct Current (DC), find the proper horsepower in the left hand column.
- On the line showing proper horsepower, move to the right until reaching the column headed by the operating voltage to be used.
- At this intersection the maximum ampere load is listed. For example, a 100 HP motor operating at 460 volts three-phase current draws 124 amperes.
- Once maximum ampere load is known, we can determine the size of electrical cable (AWG) required by using Chart C. In the above example, 124 amperes calls for #1/0 cable at 60°C; #1 at 75°C, etc.
- To comply with CSA requirements, Types SOW or WOW must be used on outdoor applications.
- Caution:** Voltage drop and power factor corrections frequently require an increase in size of conductors required.

Use the 75° column for standard cables. Contact the cable manufacturer or Aero-Motive if higher temperature ratings are required.

Chart A AMPERAGES FOR AC MOTORS

Induction type — Full load currents listed in amps

HP	115V	230V	460V	575V	2300V
.5	4	2	1	.8	
.75	5.6	2.8	1.4	1.1	
1	7.2	3.6	1.8	1.4	
1.5	10.4	5.2	2.6	2.1	
2	13.6	6.8	3.4	2.7	
3		9.6	4.8	3.9	
5		15.2	7.6	6.1	
7.5		22	11	9	
10		28	14	11	
15		42	21	17	
20		54	27	22	
25		68	34	27	
30		80	40	32	
40		104	52	41	
50		130	65	52	
60		154	77	62	16
75		192	96	77	20
100		248	124	99	26
125		312	156	125	31
150		360	180	144	37
200		480	240	192	49

For full-load currents of 208- and 200-volt motors, increase the corresponding 220-volt motor full-load current by 6 and 10 percent, respectively.

These values of full-load current are for motors running at speeds usual for belted motors and motors with normal torque characteristics. Motors built for especially low speeds or high torques may require more running current, and multispeed motors will vary full-load current according to speed, in which case the nameplate current rating should be used.

Chart B AMPERAGES FOR DC MOTORS

Motors running at full speed — Full load current listed in amps

HP	120V	240V	HP	120V	240V
.25	2.9	1.5	15		55
.33	3.6	1.5	20		72
.5	5.2	2.6	25		89
.75	7.4	3.7	30		106
1	9.4	4.7	40		140
1.5	13.2	6.6	50		173
2	17	8.5	60		206
3	25	12.2	75		255
5	40	20	100		341
7.5	58	29	125		425
10	76	38	150		506
			200		675

Chart C CABLE SELECTOR

Based on three-conductor cables

Temperature Rating of Conductor

Size AWG	60°C 140°F	75°C 167°F	85°-90°C 185°F	110°C 230°F	125°C 257°F	200°C 392°F
14	15	15	25	30	30	30
12	20	20	30	35	40	40
10	30	30	40	45	50	55
8	40	45	50	60	65	70
6	55	65	70	80	85	95
4	70	85	90	105	115	120
3	80	100	105	120	130	145
2	95	115	120	135	145	165
1	110	130	140	160	170	190
1/0	125	150	155	190	200	225
2/0	145	175	185	215	230	250
3/0	165	200	210	245	265	285
4/0	195	230	235	275	310	340
250	215	255	270	315	335	...
300	240	285	300	345	380	...
350	240	310	325	390	420	...
400	280	335	360	420	450	...
500	320	380	405	470	500	...

Notes:

- Use the highest available voltage to keep wire size to a minimum.
- If cable is to stand idle ON reel for long periods at full electric load, contact Aero-Motive, as derating may be required.
- Always specify maximum available cable stranding to ensure flexibility and long life of the cable.
- For short time cable ratings, refer to the National Electric Code.
- If fourth conductor is to be a ground wire, use the three-conductor rating.

Chart D MAGNET SIZE TO CABLE SIZE

Nominal Magnet Diam.(in.)	Cold Current (Amps.)	Cable Size* (AWG)	Nominal Magnet Diam.(in.)	Cold Current (Amps.)	Cable Size* (AWG)
39	31	#8	67	86	#2
47	43	#6	68	96	#2
58	67	#4	68	100	#2
58	73	#4	84	134	#1/0

*Recommended cable size for estimating purposes. For exact cable recommendations contact the magnet manufacturer. Use for cable lengths of 125 feet or less.

Cable Diameters and Net Weights

Type **SO** Cable **600** Volts

18 AWG				16 AWG				14 AWG				12 AWG				10 AWG			
No. of Cond.	Amps	Diam. (in.)	Weight lbs./ft.	No. of Cond.	Amps	Diam. (in.)	Weight lbs./ft.	No. of Cond.	Amps	Diam. (in.)	Weight lbs./ft.	No. of Cond.	Amps	Diam. (in.)	Weight lbs./ft.	No. of Cond.	Amps	Diam. (in.)	Weight lbs./ft.
2	7.0	.390	.0814	2	10.0	.405	.0913	2	15.0	.530	.1507	2	20.0	.605	.2068	2	25.0	.645	.2431
3	7.0	.405	.0968	3	10.0	.430	.1122	3	15.0	.560	.1859	3	20.0	.640	.2530	3	25.0	.695	.3113
4	5.6	.435	.1168	4	8.0	.485	.1495	4	12.0	.605	.2209	4	16.0	.670	.2970	4	20.0	.750	.3850
5	5.6	.495	.1408	5	8.0	.525	.1683	5	12.0	.685	.2882	5	16.0	.730	.3509	5	20.0	.815	.4609
6	5.6	.525	.1606	6	8.0	.565	.1947	6	12.0	.740	.3322	6	16.0	.800	.4092	6	20.0	.880	.5324
7		.565	.1815	7		.605	.2222	7		.795	.3619	7		.860	.4719	7		.980	.6490
8		.600	.2024	8		.645	.2431	8		.845	.4073	8		.915	.5192	8		1.050	.7172
9		.640	.2200	9		.720	.2926	9		.905	.4554	9		1.015	.6028	9		1.125	.7942
10		.640	.2288	10		.720	.3058	10		.905	.4774	10		1.015	.6347	10		1.125	.8382
12		.660	.2508	12		.740	.3355	12		.930	.5291	12		1.045	.7062	12		1.155	.9383
14		.715	.3058	14		.775	.3828	14		.980	.6116	14		1.100	.8140	16		1.290	1.2331
16		.760	.3454	16		.825	.4246	16		1.075	.7227	16		1.155	.9207	20		1.460	1.5510
18		.800	.3817	18		.860	.4730	18		1.125	.7854	18		1.225	1.0153	24		1.600	1.8095
20		.835	.4158	20		.900	.5126	20		1.180	.8646	20		1.285	1.1022	26		1.600	1.9228
22		.870	.4499	22		.940	.5588	22		1.230	.9427	22		1.375	1.2584				
24		.910	.4774	24		1.015	.6303	24		1.290	1.0120	24		1.445	1.3530				
26		.910	.5027	26		1.015	.6644	26		1.290	1.0846	26		1.445	1.4245				
28		.995	.5957	28		1.070	.7194	28		1.400	1.2078	28		1.525	1.5455				
30		.995	.5962	30		1.070	.7447	30		1.400	1.2518	30		1.525	1.6038				
32		1.035	.6380	32		1.115	.7854	32		1.460	1.3420								
34		1.070	.6765	34		1.155	.8591	34		1.510	1.4300								
36		1.070	.6930	36		1.155	.8877	36		1.510	1.4718								
40		1.140	.7733	40		1.235	.9823												
44		1.180	.8184	44		1.275	1.0208												
48		1.200	.8668	48		1.295	1.1000												
52		1.230	.9306	52		1.365	1.2287												
56		1.230	.9955	56		1.410	1.3079												
60		1.305	1.0549																

Note: The current capacity of each conductor in Type SO cable with 4 or more conductors is as follows:
 4 to 6 conductors - 80% of values shown
 7 to 24 conductors - 70% of values shown
 25 to 42 conductors - 60% of values shown
 43 or more conductors - 50% of values shown

All Pow-R-Matic Reels listed in this catalog have capacities based on the figures shown here. Due to the importance of cable weight and diameter in figuring reel capacities, the listings below are conservative to compensate for manufacturing variations in cable O.D. and weight. Should you intend using a cable of larger diameter or greater weight than shown, please advise the factory. Ampere ratings are based on 75°C insulation. Higher ratings may be obtained with other insulations. Refer to the National Electric Code for details.

Please note: A cable's amperage rating is affected by many factors including ambient temperature, amount of cable stacked on spool, and number of conductors carrying load. Cable ratings here are based on a 360°C ambient and cable in free air not wound on spool.

Type **W** Cable **600** Volts

Wire Size AWG	No. of Cond.	Current Cap., Amps.	Diameter, inches	Weight lbs./Ft.
8	2	45	.81	.407
	3	45	.90	.528
	4	36	.99	.693
	6	36	1.19	.865
6	2	65	.93	.583
	3	65	.99	.781
	4	52	1.10	.957
4	6	52	1.36	1.138
	2	85	1.08	.841
	3	85	1.20	1.155
3	4	68	1.32	1.424
	2	100	1.22	.946
	3	100	1.27	1.265
2	4	80	1.40	1.551
	2	115	1.27	1.067
	3	115	1.34	1.402
1	4	92	1.55	1.848
	2	130	1.44	1.430
	3	130	1.51	1.842
1/0	4	104	1.75	2.332
	2	150	1.50	1.573
	3	150	1.65	2.145
2/0	4	120	1.88	2.646
	2	175	1.65	1.908
	3	175	1.75	2.299
3/0	4	140	2.02	4.059
	2	200	1.77	2.442
	3	200	1.97	3.630
4/0	4	160	2.15	4.697
	2	230	1.92	3.740
	3	230	2.10	4.455
	4	184	2.34	5.764

Type **G** Cable **600** Volts

Wire Size AWG	No. of Cond.	Current Cap., Amps.	Diameter, inches	Weight lbs./Ft.
8	2	45	.81	.440
	3	45	.91	.572
	4	34	.99	.742
6	2	65	.93	.654
	3	65	1.01	.841
	4	52	1.10	1.034
4	2	85	1.08	.957
	3	85	1.20	1.265
	4	68	1.30	1.540
3	2	100	1.16	1.089
	3	100	1.26	1.364
	4	80	1.36	1.771
2	2	115	1.27	1.265
	3	115	1.34	1.573
	4	92	1.55	2.007
1	2	130	1.44	1.688
	3	130	1.51	2.112
	4	104	1.75	2.607
1/0	2	150	1.52	1.870
	3	150	1.65	2.431
	4	120	1.87	2.959
2/0	2	175	1.65	2.255
	3	175	1.75	2.838
	4	140	2.02	3.630
3/0	2	200	1.80	2.860
	3	200	1.97	3.608
	4	160	2.15	4.631
4/0	2	230	2.00	3.245
	3	230	2.10	4.191
	4	184	2.34	5.610

Dimensions

Series 900 Reels

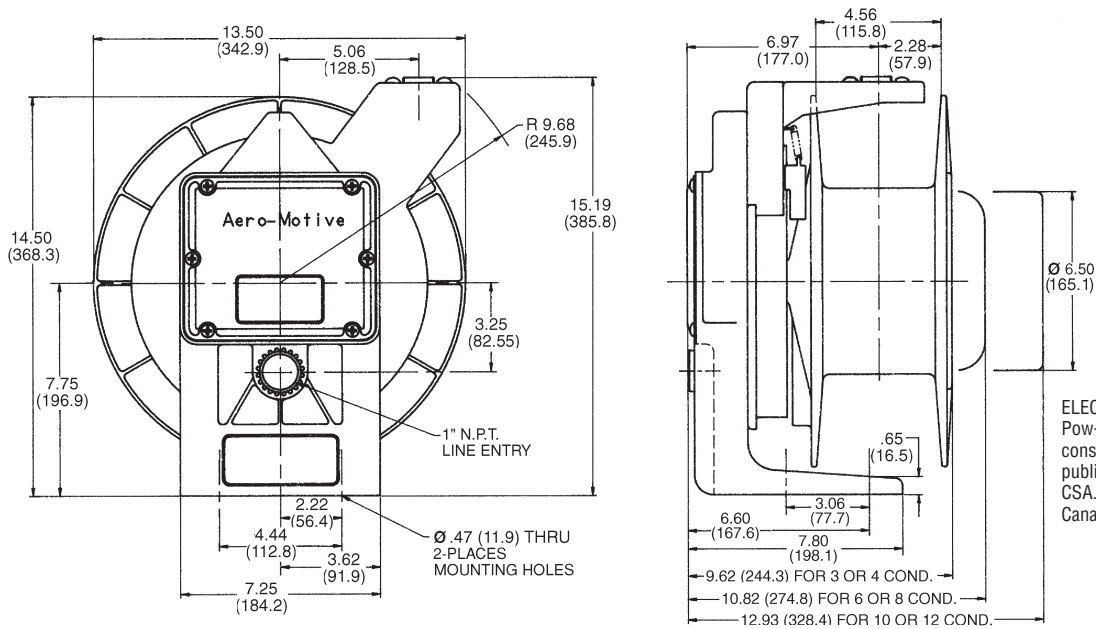

ELECTRIFICATION LISTINGS
Pow-R-Mite Cable Reels are
constructed to standards
published by NEC, UL, and
CSA. All reels shipped in
Canada are CSA approved.

ERA4000 Series Welding Reels are dimensioned the same as the 4 Conductor Model Above.

Series 1000 Reels

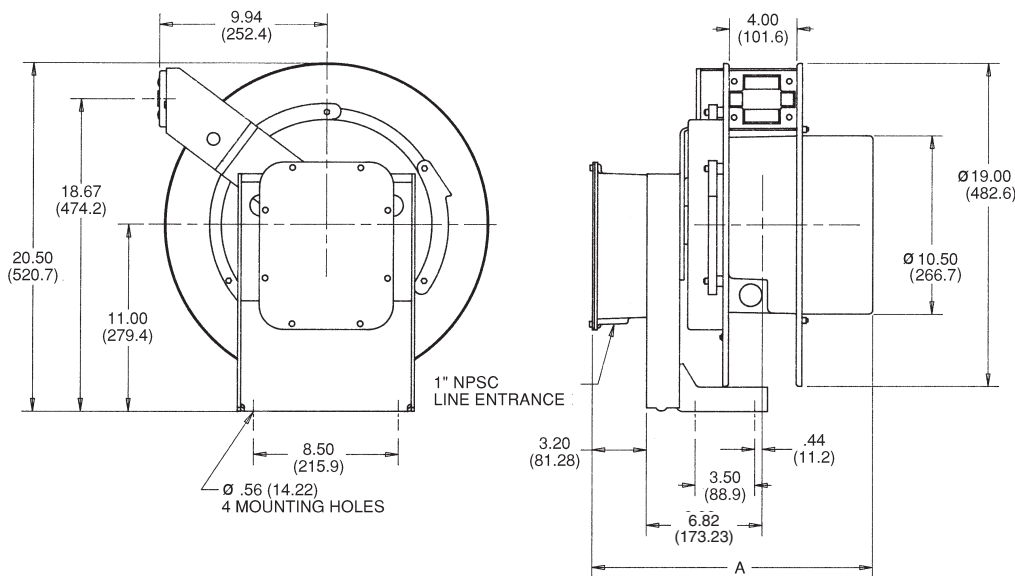

Model	Dim. A in. mm	Weight Lbs.
1051-xx-302	16.67 423	81
1051-xx-303		81
1051-xx-304		81
1051-xx-306		82
1051-xx-402		81
1051-xx-403		81
1051-xx-308	18.84 479	82
1051-xx-310		83
1051-xx-312		83
1051-xx-404		82
1051-xx-405		83
1051-xx-314	21.65 500	84
1051-xx-316		84
1051-xx-902		82
1051-xx-320	25.00 635	86

Chart shows dimensional variables within a reel series – “xx”
in the catalog number listing represents the drive system and
does not affect reel dimensions.

See page 35 for slip ring rating and junction box detail.

Series 1100M Reels

Chart shows dimensional variables within a reel series – “xx” in the catalog number listing represents the drive system and does not affect reel dimensions. See page 38 for slip ring rating and junction box detail.

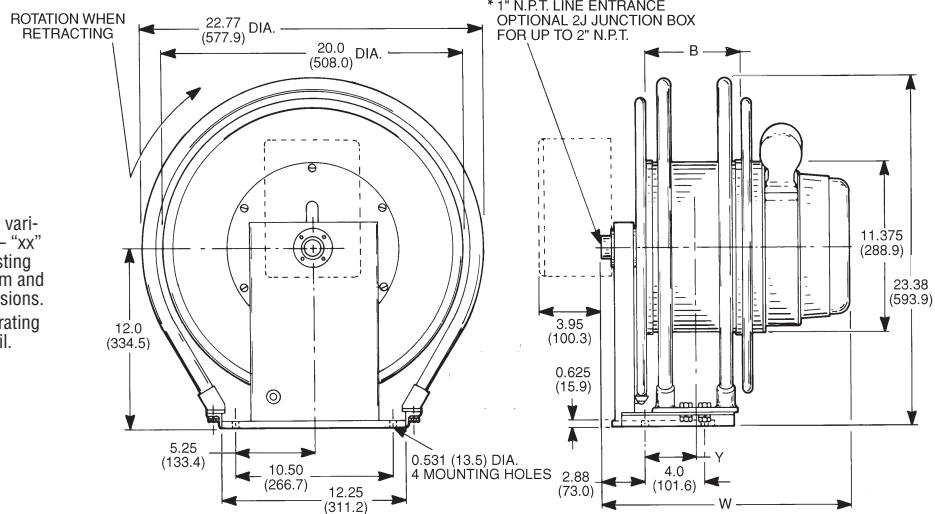

Model	Dim. B in. mm	Dim. Y in. mm	Dim. W in. mm	Weight lbs. Kg
1122-xx-303	2.25 57.2	1.25 31.8	14.25 362.0	114 51.8
304	2.25 57.2	1.25 31.8	14.25 362.0	114 51.8
306	2.25 57.2	1.25 31.8	16.25 412.8	115 52.2
308	2.25 57.2	1.25 31.8	16.25 412.8	116 52.7
310	2.25 57.2	1.25 31.8	18.25 463.6	117 53.1
312	2.25 57.2	1.25 31.8	18.25 463.6	118 53.6
316	2.25 57.2	1.25 31.8	20.25 514.4	120 54.5
320	2.25 57.2	1.25 31.8	22.25 565.2	123 55.8
324	2.25 57.2	1.25 31.8	24.25 616.0	125 56.8
330	2.25 57.2	1.25 31.8	28.25 717.6	128 58.1
336	2.25 57.2	1.25 31.8	30.25 768.4	131 59.5
402	2.25 57.2	1.25 31.8	16.25 412.8	115 52.2
403	2.25 57.2	1.25 31.8	16.25 412.8	115 52.2
404	2.25 57.2	1.25 31.8	16.25 412.8	116 52.7
902	2.25 57.2	1.25 31.8	18.25 463.6	116 52.7
903	2.25 57.2	1.25 31.8	18.25 463.6	117 53.1
904	2.25 57.2	1.25 31.8	20.25 514.4	119 54.0

Model	Dim. B in. mm	Dim. Y in. mm	Dim. W in. mm	Weight lbs. Kg
1142-xx-303	4.25 108	2.25 57.2	14.25 362.0	114 51.8
304	4.25 108	2.25 57.2	14.25 362.0	114 51.8
306	4.25 108	2.25 57.2	16.25 412.8	115 52.2
308	4.25 108	2.25 57.2	16.25 412.8	116 52.7
310	4.25 108	2.25 57.2	18.25 463.6	117 53.1
312	4.25 108	2.25 57.2	18.25 463.6	118 53.6
316	4.25 108	2.25 57.2	20.25 514.4	120 54.5
320	4.25 108	2.25 57.2	22.25 565.2	123 55.8
324	4.25 108	2.25 57.2	24.25 616.0	125 56.8
330	4.25 108	2.25 57.2	28.25 717.6	128 58.1
336	4.25 108	2.25 57.2	30.25 768.4	131 59.5
402	4.25 108	2.25 57.2	16.25 412.8	115 52.2
403	4.25 108	2.25 57.2	16.25 412.8	115 52.2
404	4.25 108	2.25 57.2	16.25 412.8	116 52.7
902	4.25 108	2.25 57.2	18.25 463.6	116 52.7
903	4.25 108	2.25 57.2	18.25 463.6	117 53.1
904	4.25 108	2.25 57.2	20.25 514.4	119 54.0

Model	Dim. B in. mm	Dim. Y in. mm	Dim. W in. mm	Weight lbs. Kg
1143-xx-303	4.44 112.8	2.31 58.7	16.38 416.1	138 62.7
304	4.44 112.8	2.31 58.7	16.38 416.1	138 62.7
306	4.44 112.8	2.31 58.7	18.38 466.9	139 63.1
308	4.44 112.8	2.31 58.7	18.38 466.9	140 63.6
310	4.44 112.8	2.31 58.7	20.38 517.7	141 64.0
312	4.44 112.8	2.31 58.7	20.38 517.7	142 64.5
316	4.44 112.8	2.31 58.7	22.38 568.5	144 65.4
320	4.44 112.8	2.31 58.7	24.38 619.3	147 66.7
324	4.44 112.8	2.31 58.7	26.38 670.1	149 67.6
330	4.44 112.8	2.31 58.7	30.38 771.7	152 69.0
336	4.44 112.8	2.31 58.7	32.38 822.5	155 70.4
402	4.44 112.8	2.31 58.7	18.38 466.9	139 63.1
403	4.44 112.8	2.31 58.7	18.38 466.9	139 63.1
404	4.44 112.8	2.31 58.7	18.38 466.9	140 63.6
902	4.44 112.8	2.31 58.7	20.38 517.7	140 63.6
903	4.44 112.8	2.31 58.7	20.38 517.7	141 64.0
904	4.44 112.8	2.31 58.7	22.38 568.5	143 64.9

Model	Dim. B in. mm	Dim. Y in. mm	Dim. W in. mm	Weight lbs. Kg
1163-xx-303	6.44 163.6	3.31 84.1	16.38 416.1	138 62.7
304	6.44 163.6	3.31 84.1	16.38 416.1	138 62.7
306	6.44 163.6	3.31 84.1	18.38 466.9	139 63.1
308	6.44 163.6	3.31 84.1	18.38 466.9	140 63.6
310	6.44 163.6	3.31 84.1	20.38 517.7	141 64.0
312	6.44 163.6	3.31 84.1	20.38 517.7	142 64.5
316	6.44 163.6	3.31 84.1	22.38 568.5	144 65.4
320	6.44 163.6	3.31 84.1	24.38 619.3	149 67.6
324	6.44 163.6	3.31 84.1	26.38 670.1	149 67.6
330	6.44 163.6	3.31 84.1	32.38 822.5	155 70.4
402	6.44 163.6	3.31 84.1	18.38 466.9	139 63.1
403	6.44 163.6	3.31 84.1	18.38 466.9	139 63.1
404	6.44 163.6	3.31 84.1	18.38 466.9	140 63.6
902	6.44 163.6	3.31 84.1	20.38 517.7	140 63.6
903	6.44 163.6	3.31 84.1	20.38 517.7	141 64.0
904	6.44 163.6	3.31 84.1	22.38 568.5	143 64.9

Model	Dim. B in. mm	Dim. Y in. mm	Dim. W in. mm	Weight lbs. Kg
1164-xx-303	6.63 168.4	3.44 87.4	18.63 473.2	163 74.0
304	6.63 168.4	3.44 87.4	18.63 473.2	163 74.0
306	6.63 168.4	3.44 87.4	20.63 524.0	164 74.5
308	6.63 168.4	3.44 87.4	20.63 524.0	165 74.9
310	6.63 168.4	3.44 87.4	22.63 574.8	166 75.4
312	6.63 168.4	3.44 87.4	22.63 574.8	167 75.8
316	6.63 168.4	3.44 87.4	24.63 625.6	169 76.7
320	6.63 168.4	3.44 87.4	26.63 676.4	172 78.1
324	6.63 168.4	3.44 87.4	28.63 727.2	174 79.0
330	6.63 168.4	3.44 87.4	32.63 828.0	177 80.4
336	6.63 168.4	3.44 87.4	34.63 879.6	180 81.7
402	6.63 168.4	3.44 87.4	20.63 524.0	164 74.5
403	6.63 168.4	3.44 87.4	20.63 524.0	164 74.5
404	6.63 168.4	3.44 87.4	20.63 524.0	165 74.9
902	6.63 168.4	3.44 87.4	22.63 574.8	165 74.9
903	6.63 168.4	3.44 87.4	22.63 574.8	166 75.4
904	6.63 168.4	3.44 87.4	24.63 625.6	168 76.3

Model	Dim. B in. mm	Dim. Y in. mm	Dim. W in. mm	Weight lbs. Kg
1165-xx-303	6.63 168.4	3.44 87.4	20.75 527.1	188 85.4
304	6.63 168.4	3.44 87.4	20.75 527.1	188 85.4
306	6.63 168.4	3.44 87.4	22.75 577.9	189 85.8
308	6.63 168.4	3.44 87.4	22.75 577.9	190 86.3
310	6.63 168.4	3.44 87.4	24.75 628.9	191 86.7
312	6.63 168.4	3.44 87.4	24.75 628.9	192 87.2
316	6.63 168.4	3.44 87.4	26.75 679.5	194 88.1
320	6.63 168.4	3.44 87.4	28.75 730.3	197 89.4
324	6.63 168.4	3.44 87.4	30.75 781.1	199 90.3
330	6.63 168.4	3.44 87.4	34.75 882.7	202 91.7
336	6.63 168.4	3.44 87.4	36.75 933.5	205 93.1
402	6.63 168.4	3.44 87.4	22.75 577.9	189 85.8
403	6.63 168.4	3.44 87.4	22.75 577.9	198 85.8
404	6.63 168.4	3.44 87.4	22.75 577.9	190 86.3
902	6.63 168.4	3.44 87.4	24.75 628.7	190 86.3
903	6.63 168.4	3.44 87.4	24.75 628.7	191 86.7
904	6.63 168.4	3.44 87.4	26.75 679.5	193 87.6
ER61000	6.44 163.6	3.31 84.1	16.38 416.1	138 62.7

Dimensions

Series 1200M & 1300M Reels

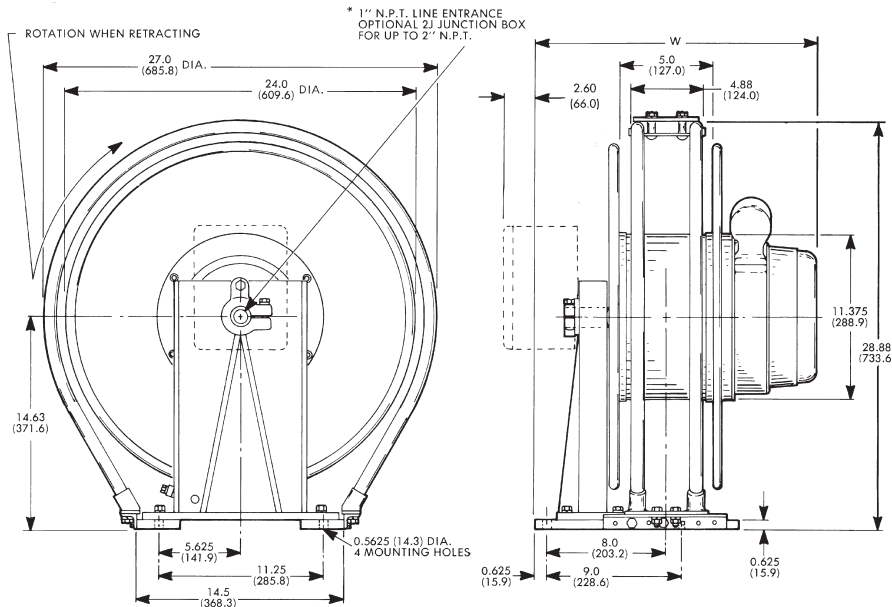

Chart shows dimensional variables within a reel series - "xx" in the catalog number listing represents the drive system and does not affect reel dimensions. See page 35 for slip ring rating and junction box detail.

Model	Dim. W in. mm	Weight lbs. Kg
1253-xx-303	19.38 492.3	172 78.1
304	19.38 492.3	172 78.1
306	21.38 543.1	173 78.5
308	21.38 543.1	174 79.0
310	23.38 593.9	175 79.5
312	23.38 593.9	176 79.9
316	25.38 644.7	178 80.8
320	27.38 695.5	181 82.2
324	29.38 746.3	183 83.1
330	33.38 847.9	186 84.4
336	35.38 898.7	189 85.8
402	21.38 543.1	173 78.5
403	21.38 543.1	173 78.5
404	21.38 543.1	174 79.0
902	23.38 593.9	174 79.0
903	23.38 593.9	175 79.5
904	25.38 644.7	177 80.4

1255-xx-303	23.75 603.3	221 100.3
304	23.75 603.3	221 100.3
306	25.75 654.1	222 100.9
308	25.75 654.1	223 101.2
310	27.75 704.9	224 101.7
312	27.75 704.9	225 102.2
316	29.75 755.6	227 103.1
324	33.75 857.3	232 105.3
330	37.75 958.9	235 106.7
336	39.75 1009.7	238 108.0
402	25.75 654.1	222 100.8
403	25.75 654.1	222 100.8
404	25.75 654.1	223 101.2
902	27.75 704.9	223 101.2
903	27.75 704.9	224 101.7
904	29.75 755.6	226 102.6

Model	Dim. W in. mm	Weight lbs. Kg
1257-xx-303	28.12 714.3	271 123.0
304	28.12 714.3	271 123.0
306	30.12 765.1	272 123.5
308	30.12 765.1	273 123.9
310	32.12 815.9	274 124.4
312	32.12 815.9	275 124.9
316	34.12 866.7	277 125.8
320	36.12 917.5	280 127.1
324	38.12 968.3	282 128.0
330	42.12 1069.9	285 129.4
336	44.12 1120.7	288 130.8
402	30.12 765.1	272 123.5
403	30.12 765.1	272 123.5
404	30.12 765.1	273 123.9
902	32.12 815.9	273 123.9
903	32.12 815.9	274 124.4
904	34.12 866.7	276 125.3

1354-xx-306	23.56 547	198 90.0
308	23.56 547	199 90.5
310	25.56 649	200 90.9
312	25.56 649	201 91.3
316	27.56 700	203 92.2
320	29.56 751	206 93.6
324	31.56 802	208 94.5
330	35.56 903	198 90.0
404	23.56 547	199 90.5
902	25.56 649	199 90.5
903	25.56 649	200 90.9
904	27.56 700	202 91.8

1356-xx-304	25.93 659	246 111.8
306	27.93 709	247 112.3
308	27.93 709	248 112.7
310	29.93 760	249 113.2
312	29.93 760	250 113.6
316	31.93 811	252 114.5
320	33.93 862	254 115.5
402	27.93 709	247 112.3
403	27.93 709	247 112.3
404	27.93 709	248 112.4

Series 1400M & 1500M Reels

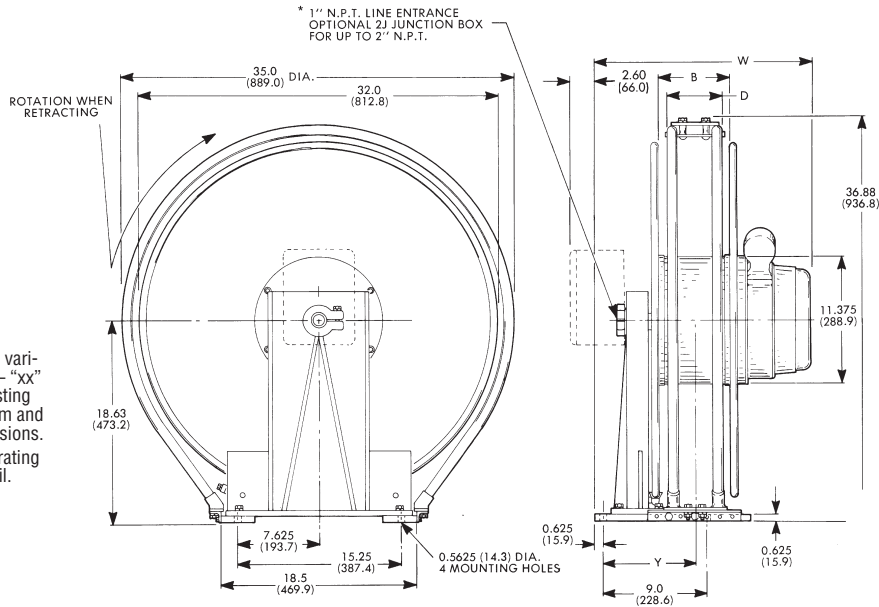

Chart shows dimensional variables within a reel series – “xx” in the catalog number listing represents the drive system and does not affect reel dimensions. See page 35 for slip ring rating and junction box detail.

Series No.	Dim. B in. mm	Dim. D in. mm	Dim. Y in. mm
1443, 1445 & 1446	4.0 101.6	4.88 124.0	7.63 193.8
1544&1546			
1475&1476	7.0 177.8	6.19 157.2	9.13 231.9
1574&1576			

Model	Dim. W in. mm	Weight lbs. Kg
1476-xx-320	34.06 865.1	313 142.1
324	36.06 915.9	315 143.0
330	40.06 1017.5	318 144.4
336	42.06 1068.3	321 145.7
402	28.06 712.7	305 138.5
403	28.06 712.7	305 138.5
404	28.06 712.7	306 138.9
902	30.06 763.5	306 138.9
903	30.06 763.5	307 139.4
904	32.06 814.3	309 140.3

Model	Dim. W in. mm	Weight lbs. Kg
1443-xx-303	19.56 496.8	229 104.0
304	19.56 496.8	229 104.0
306	21.56 547.6	230 104.4
308	21.56 547.6	231 104.9
310	23.56 598.4	232 105.3
312	23.56 598.4	233 105.8
316	25.56 649.2	235 106.7
320	27.56 700.0	238 108.1
324	29.56 750.8	240 109.0
330	33.56 852.4	243 110.3
336	35.56 903.2	246 111.7
402	21.56 547.6	230 104.4
403	21.56 547.6	230 104.4
404	21.56 547.6	231 104.9
902	23.56 598.4	231 104.9
903	23.56 598.4	232 105.3
904	25.56 649.2	234 106.2
1445-xx-303	23.88 606.5	279 126.7
304	23.88 606.5	279 126.7
306	25.88 657.4	280 127.1
308	25.88 657.4	281 127.6
310	27.88 708.2	282 128.0
312	27.88 708.2	283 128.5
316	29.88 759.0	285 129.4
320	31.88 809.8	288 130.8
324	33.88 860.6	290 131.7
330	37.88 962.2	293 133.0
336	39.88 1013.0	296 134.4
402	25.88 657.4	280 127.1
403	25.88 657.4	280 127.1
404	25.88 657.4	281 127.6
902	27.88 708.2	281 127.6
903	27.88 708.2	282 128.0
904	29.88 759.0	284 128.9
1446-xx-303	26.06 661.9	304 138.0
304	26.06 661.9	304 138.0
306	28.06 712.7	305 138.5
308	28.06 712.7	305 138.5

Model	Dim. W in. mm	Weight lbs. Kg
1446-xx-310	30.06 763.5	307 139.4
312	30.06 763.5	308 139.8
316	32.06 814.3	310 140.7
320	34.06 865.1	313 142.1
1446-xx-324	36.06 915.9	315 143.0
330	40.06 1017.5	318 144.4
336	42.06 1068.3	321 145.7
402	28.06 712.7	305 138.5
403	28.06 712.7	305 138.5
404	28.06 712.7	306 138.9
902	30.06 763.5	306 138.9
903	30.06 763.5	307 139.4
904	32.06 814.3	309 140.3
1475-xx-303	23.88 606.5	279 126.7
304	23.88 606.5	279 126.7
306	25.88 657.4	280 127.1
308	25.88 657.4	281 127.6
310	27.88 708.2	282 128.0
312	27.88 708.2	283 128.5
316	29.88 759.0	285 129.4
320	31.88 809.8	288 130.8
324	33.88 860.6	290 131.7
330	37.88 962.2	293 133.0
336	39.88 1013.0	296 134.4
402	25.88 657.4	280 127.1
403	25.88 657.4	280 127.1
404	25.88 657.4	281 127.6
902	27.88 708.2	281 127.6
903	27.88 708.2	282 128.0
904	29.88 759.0	284 128.9
1476-xx-303	26.06 661.9	304 138.0
304	26.06 661.9	304 138.0
306	28.06 712.7	305 138.5
308	28.06 712.7	305 138.5
310	30.06 763.5	307 139.4
312	30.06 763.5	308 139.8
316	32.06 814.3	310 140.7

Model	Dim. W in. mm	Weight lbs. Kg
1544-xx-306	23.74 603.0	255 115.9
308	23.74 603.0	256 116.4
310	25.74 653.8	257 116.8
312	25.74 653.8	258 117.3
316	27.74 704.6	260 118.2
320	29.74 755.4	263 119.5
324	31.74 806.2	265 120.5
330	35.74 907.8	268 121.8
336	37.74 958.6	271 123.2
402	23.74 603.0	255 115.9
403	23.74 603.0	255 115.9
404	23.74 603.0	256 116.4
902	25.74 653.8	256 116.4
903	25.74 653.8	257 116.8
904	27.74 704.6	259 117.7

Model	Dim. W in. mm	Weight lbs. Kg
1546-xx-304	26.06 661.9	304 138.0
306	28.06 712.7	305 138.5
308	28.06 712.7	306 138.9
310	30.06 763.5	307 139.4
312	30.06 763.5	308 139.8
316	32.06 814.3	310 140.7
320	34.06 865.1	313 142.1
402	28.06 712.7	305 138.5
403	28.06 712.7	305 138.5
404	28.06 712.7	306 138.9

Model	Dim. W in. mm	Weight lbs. Kg
1574-xx-324	31.74 806.2	265 120.5
330	35.74 907.8	268 121.8
336	37.74 958.6	271 123.2
902	25.74 653.8	256 116.4

Model	Dim. W in. mm	Weight lbs. Kg
1576-xx-320	34.06 865.1	313 142.1
324	36.06 915.9	315 143.0
330	40.06 1017.5	318 144.4
336	42.06 1068.3	321 145.7
902	30.06 763.5	306 138.9
903	30.06 763.5	307 139.4
904	32.06 814.3	309 140.4

Dimensions

Series 2000 Reels

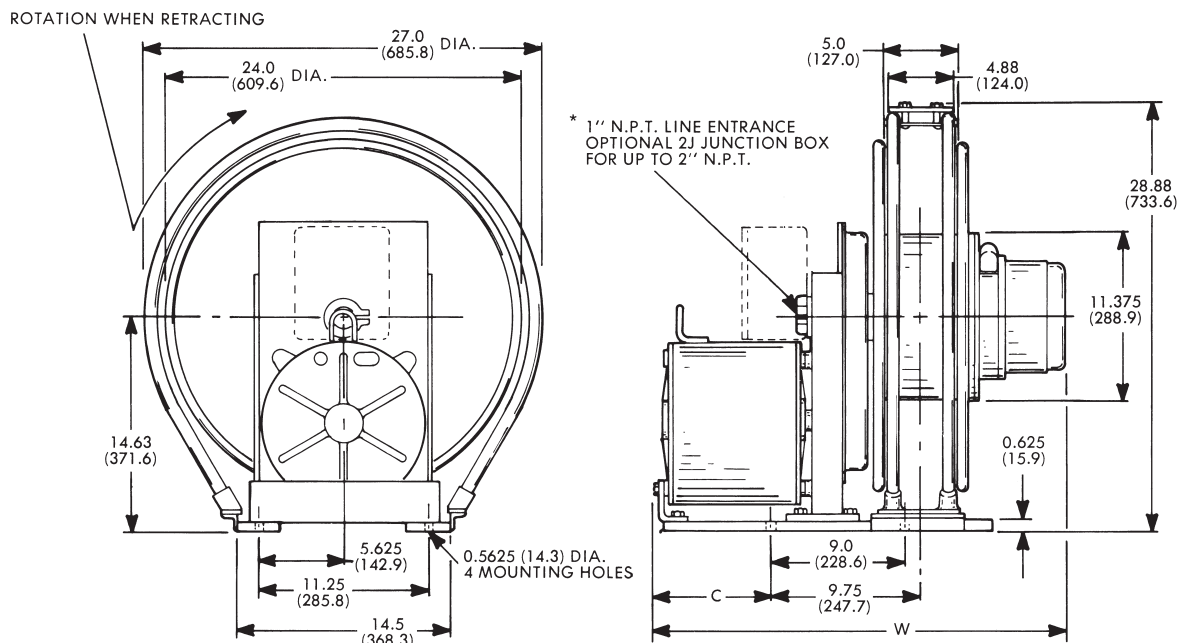

Chart shows dimensional variables within a reel series - "xx" in the catalog number listing represents the drive system and does not affect reel dimensions.

See page 38 for slip ring rating and junction box detail.
MILL DUTY SERVICE OPTION (Page 28)
will increase Dimensions C and W by 2.86 inches (73 mm)

Model	Dim. C in. mm	Dim. W in. mm	Weight lbs. Kg
2050-xx-303	21.88 555.8	41.88 1063.8	358 162.5
306	21.88 555.8	43.88 1114.6	360 163.4
2053-xx-306	6.75 171.5	27.38 695.5	214 97.2
308	6.75 171.5	27.38 695.5	215 97.6
310	6.75 171.5	29.38 746.3	216 98.1
312	6.75 171.5	29.38 746.3	217 98.5
316	6.75 171.5	31.38 797.1	218 99.0
320	6.75 171.5	33.38 847.9	222 100.8
324	6.75 171.5	35.38 898.7	224 101.7
330	6.75 171.5	39.38 1002.5	227 103.1
336	6.75 171.5	41.38 1051.1	229 104.0
402	6.75 171.5	27.38 695.5	213 96.7
403	6.75 171.5	27.38 695.5	214 97.2
404	6.75 171.5	27.38 695.5	214 97.2
902	6.75 171.5	29.38 746.3	215 97.6
903	6.75 171.5	29.38 746.3	216 98.1
904	6.75 171.5	31.38 797.1	217 98.5
2054-xx-306	8.88 225.6	30.88 784.4	235 106.7
308	8.88 225.6	30.88 784.4	236 107.2
310	8.88 225.6	32.88 835.2	237 107.6
312	8.88 225.6	32.88 835.2	237 107.6
316	8.88 225.6	34.88 886.0	239 108.5
330	8.88 225.6	42.88 1089.2	247 112.1
336	8.88 225.6	44.88 1140.0	250 113.5
402	8.88 225.6	30.88 784.4	234 106.2
403	8.88 225.6	30.88 784.4	235 106.7
404	8.88 225.6	30.88 784.4	235 106.7
902	8.88 225.6	32.88 835.2	235 106.7
903	8.88 225.6	32.88 835.2	237 107.6
904	8.88 225.6	34.88 886.0	238 108.1
2055-xx-303	11.12 282.5	31.00 787.4	254 115.3
304	11.12 282.5	31.00 787.4	255 115.8
306	11.12 282.5	33.00 838.2	256 116.2
308	11.12 282.5	33.00 838.2	257 116.7
310	11.12 282.5	35.00 889.0	257 116.7
312	11.12 282.5	35.00 889.0	258 117.1

Model	Dim. C in. mm	Dim. W in. mm	Weight lbs. Kg
316	11.12 282.5	37.00 939.8	260 118.0
320	11.12 282.5	39.00 990.6	264 119.9
402	11.12 282.5	33.00 838.2	255 115.8
403	11.12 282.5	33.00 838.2	256 116.2
404	11.12 282.5	33.00 838.2	256 116.2
904	11.12 282.5	37.00 939.8	259 117.6
2056-xx-303	13.25 336.6	33.25 844.6	275 124.9
304	13.25 336.6	33.25 844.6	276 125.3
306	13.25 336.6	35.25 895.4	277 125.8
308	13.25 336.6	35.25 895.4	278 126.2
310	13.25 336.6	37.25 946.2	278 126.2
312	13.25 336.6	37.25 946.2	279 126.7
316	13.25 336.6	39.25 997.0	280 127.1
320	13.25 336.6	41.25 1047.8	281 127.6
402	13.25 336.6	35.25 895.4	276 125.3
403	13.25 336.6	35.25 895.4	277 125.8
404	13.25 336.6	35.25 895.4	288 130.8
2057-xx-303	15.38 390.7	35.38 898.7	296 134.4
304	15.38 390.7	35.38 898.7	297 134.8
306	15.38 390.7	37.38 949.5	297 134.8
308	15.38 390.7	37.38 949.5	298 135.3
403	15.38 390.7	37.38 949.5	297 134.8
404	15.38 390.7	37.38 949.5	298 135.3
2058-xx-303	17.63 447.8	37.50 952.5	317 143.9
304	17.63 447.8	37.50 952.5	317 143.9
306	17.63 447.8	39.50 1003.3	318 144.4
308	17.63 447.8	39.50 1003.3	319 144.8
402	17.63 447.8	39.50 1003.3	318 144.4
403	17.63 447.8	39.50 1003.3	318 144.4
404	17.63 447.8	39.50 1003.3	319 144.8
2059-xx-303	19.75 501.7	39.75 1009.7	338 153.5
304	19.75 501.7	39.75 1009.7	338 153.5
306	19.75 501.7	41.75 1060.5	339 153.9
308	19.75 501.7	41.75 1060.5	341 154.8
404	19.75 501.7	41.75 1060.5	340 154.4

Series 2300 Reels

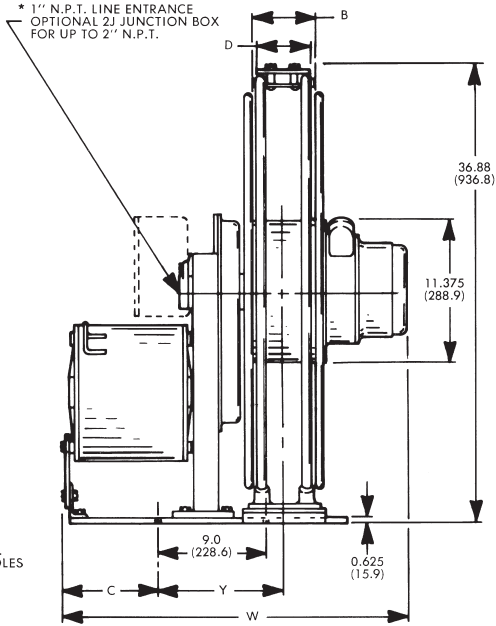
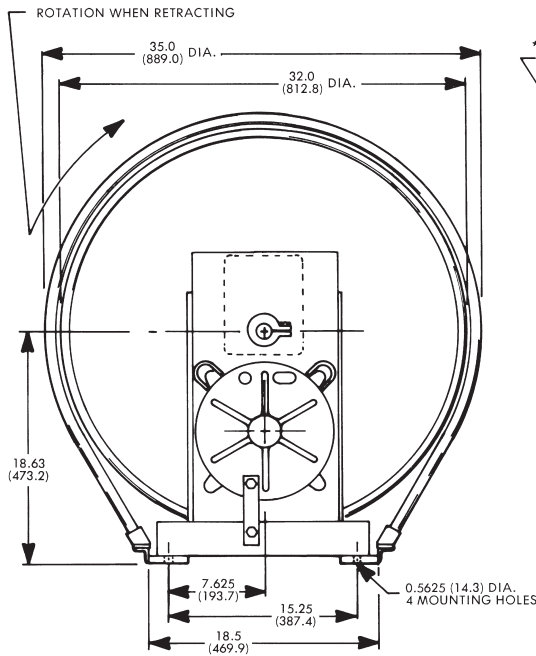

Series No.	Dim. B		Dim. D		Dim. Y	
	in.	mm	in.	mm	in.	mm
2340	4.00	101.6	4.88	124.0	9.25	235.0
2343	4.00	101.6	4.88	124.0	9.25	235.0
2344	4.00	101.6	4.88	124.0	9.25	235.0
2345	4.00	101.6	4.88	124.0	9.25	235.0
2346	4.00	101.6	4.88	124.0	9.25	235.0
2347	4.00	101.6	4.88	124.0	9.25	235.0
2348	4.00	101.6	4.88	124.0	9.25	235.0
2349	4.00	101.6	4.88	124.0	9.25	235.0
2370	7.00	177.8	6.19	157.2	10.75	273.1
2374	7.00	177.8	6.19	157.2	10.75	273.1
2375	7.00	177.8	6.19	157.2	10.75	273.1
2376	7.00	177.8	6.19	157.2	10.75	273.1
2377	7.00	177.8	6.19	157.2	10.75	273.1
2378	7.00	177.8	6.19	157.2	10.75	273.1
2379	7.00	177.8	6.19	157.2	10.75	273.1

Chart shows dimensional variables within a reel series – “xx” in the catalog number listing represents the drive system and does not affect reel dimensions.

See page 35 for slip ring rating and junction box detail.

MILL DUTY SERVICE OPTION (Page 28)
will increase Dimensions C and W by 2.86 inches (73 mm)

Model	Dim. C		Dim. W		Weight	
	in.	mm	in.	mm	lbs.	Kg
2340-xx-304	21.88	555.8	40.38	1025.7	417	189.3
306	21.88	555.8	42.38	1076.5	418	189.3
308	21.88	555.8	42.38	1076.5	419	190.2
310	21.88	555.8	44.38	1127.3	420	190.7
312	21.88	555.8	44.38	1127.3	422	191.6
402	21.88	555.8	42.38	1076.5	418	189.8
403	21.88	555.8	42.38	1076.5	418	189.8
404	21.88	555.8	42.38	1076.5	419	190.2
902	21.88	555.8	44.38	1127.3	419	190.2
904	21.88	555.8	46.38	1178.1	422	191.6
2343-xx-316	6.75	171.5	31.12	790.5	276	125.3
320	6.75	171.5	33.12	841.3	280	127.1
324	6.75	171.5	35.12	892.1	282	128.0
330	6.75	171.5	39.12	993.7	284	128.9
336	6.75	171.5	41.12	1044.5	287	130.3
404	6.75	171.5	27.12	688.9	272	123.5
902	6.75	171.5	29.12	739.7	272	123.5
903	6.75	171.5	29.12	739.7	274	124.4
904	6.75	171.5	31.12	790.5	275	124.9

Model	Dim. C		Dim. W		Weight	
	in.	mm	in.	mm	lbs.	Kg
2344-xx-308	8.88	225.6	29.38	746.3	294	133.5
310	8.88	225.6	31.38	797.1	295	133.9
312	8.88	225.6	31.38	797.1	295	133.9
316	8.88	225.6	33.38	847.9	297	134.8
320	8.88	225.6	35.38	898.7	301	136.7
324	8.88	225.6	37.38	949.5	303	137.6
330	8.88	225.6	41.38	1051.1	305	138.5
336	8.88	225.6	43.38	1101.9	308	139.8
402	8.88	225.6	29.38	746.3	292	132.6
404	8.88	225.6	29.38	746.3	293	133.0
902	8.88	225.6	31.38	797.1	293	133.0
903	8.88	225.6	31.38	797.1	295	133.9
904	8.88	225.6	33.38	847.9	296	134.4
2345-xx-304	11.12	282.5	29.50	749.3	313	142.1
306	11.12	282.5	31.50	800.1	314	142.6
308	11.12	282.5	31.50	800.1	315	143.0
310	11.12	282.5	33.50	850.9	315	143.0
312	11.12	282.5	33.50	850.9	316	143.5
316	11.12	282.5	35.50	901.7	318	144.4
320	11.12	282.5	37.50	952.5	322	146.2
324	11.12	282.5	39.50	1003.3	324	147.1
330	11.12	282.5	43.50	1104.9	326	148.0
336	11.12	282.5	45.50	1155.7	329	149.4
402	11.12	282.5	31.50	800.1	313	142.1
403	11.12	282.5	31.50	800.1	314	142.6
404	11.12	282.5	31.50	800.1	314	142.6
902	11.12	282.5	33.50	850.9	314	142.6
903	11.12	282.5	33.50	850.9	316	143.5
904	11.12	282.5	35.50	901.7	317	143.9

Continued on next page

Dimensions

Series 2300 Reels

(CONTINUED)

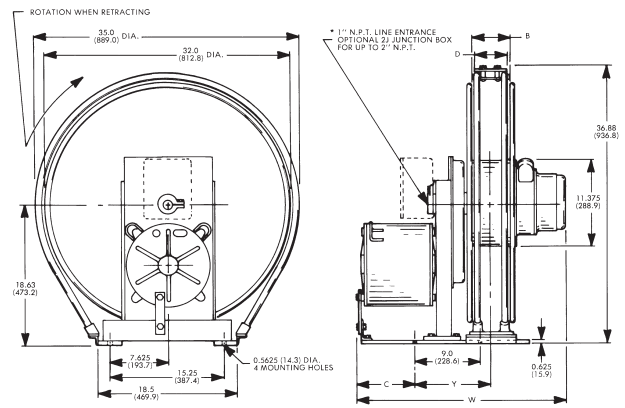

Model	Dim. C in. mm	Dim. W in. mm	Weight lbs. Kg
2346-xx-304	13.25 336.6	31.62 803.2	334 151.6
306	13.25 336.6	33.62 854.0	335 152.1
308	13.25 336.6	33.62 854.0	335 152.1
310	13.25 336.6	35.62 904.8	336 152.5
312	13.25 336.6	35.62 904.8	337 153.0
316	13.25 336.6	37.62 955.6	339 153.9
320	13.25 336.6	39.62 1006.4	343 155.7
324	13.25 336.6	41.62 1057.2	344 156.2
330	13.25 336.6	45.62 1158.8	347 157.5
336	13.25 336.6	47.62 1209.6	350 158.9
402	13.25 336.6	31.62 803.2	334 151.6
403	13.25 336.6	31.62 803.2	334 151.6
404	13.25 336.6	31.62 803.2	335 152.1
902	13.25 336.6	33.62 854.0	335 152.1
903	13.25 336.6	33.62 854.0	337 153.0
904	13.25 336.6	35.62 904.8	338 153.5
2347-xx-304	15.38 390.7	33.88 860.6	355 161.2
306	15.38 390.7	35.88 911.4	355 161.2
308	15.38 390.7	35.88 911.4	356 161.6
310	15.38 390.7	37.88 962.2	357 162.1
312	15.38 390.7	37.88 962.2	358 162.5
316	15.38 390.7	39.88 1013.0	360 163.4
320	15.38 390.7	41.88 1063.8	364 165.3
324	15.38 390.7	43.88 1114.6	365 165.7
330	15.38 390.7	47.88 1216.2	370 168.0
402	15.38 390.7	35.88 911.4	355 161.2
403	15.38 390.7	35.88 911.4	355 161.2
404	15.38 390.7	35.88 911.4	356 161.6
902	15.38 390.7	37.88 962.2	356 161.6
903	15.38 390.7	37.88 962.2	358 162.5
904	15.38 390.7	39.88 1013.0	359 163.0
2348-xx-306	17.63 447.8	38.00 965.2	376 170.7
308	17.63 447.8	38.00 965.2	377 171.2
310	17.63 447.8	40.00 1016.0	378 171.6
312	17.63 447.8	40.00 1016.0	379 172.1
316	17.63 447.8	42.00 1066.8	381 173.0
320	17.63 447.8	44.00 1117.6	382 173.4
402	17.63 447.8	38.00 965.2	376 170.7
403	17.63 447.8	38.00 965.2	376 170.7
404	17.63 447.8	38.00 965.2	377 171.2
903	17.63 447.8	40.00 1016.0	379 172.1
904	17.63 447.8	42.00 1066.8	380 172.5
2349-xx-303	19.75 495.7	38.12 968.2	395 179.3
304	19.75 495.7	38.12 968.2	396 179.8
306	19.75 495.7	40.12 1019.1	397 180.2
308	19.75 495.7	40.12 1019.1	398 180.7
310	19.75 495.7	42.12 1069.9	399 181.1
312	19.75 495.7	42.12 1069.9	400 181.6
316	19.75 495.7	44.12 1120.7	402 182.5
320	19.75 495.7	46.12 1171.5	405 183.9
402	19.75 495.7	38.12 968.2	397 180.2
403	19.75 495.7	38.12 968.2	397 180.2
404	19.75 495.7	38.12 968.2	398 180.7
902	19.75 495.7	40.12 1019.1	398 180.7
903	19.75 495.7	40.12 1019.1	404 183.4
2370-xx-306	21.88 555.8	45.38 1152.7	423 192.0
308	21.88 555.8	45.38 1152.7	424 192.5
310	21.88 555.8	47.38 1203.4	425 193.0
312	21.88 555.8	47.38 1203.4	426 193.4
316	21.88 555.8	49.38 1254.3	428 194.3
320	21.88 555.8	51.38 1305.1	431 195.7
324	21.88 555.8	53.38 1355.9	433 196.6
330	21.88 555.8	57.38 1457.5	436 197.9

Model	Dim. C in. mm	Dim. W in. mm	Weight lbs. Kg
2370-xx-336	21.88 555.8	59.38 1508.3	438 198.9
403	21.88 555.8	45.38 1152.7	423 192.0
404	21.88 555.8	45.38 1152.7	424 192.5
902	21.88 555.8	47.38 1203.4	424 192.5
903	21.88 555.8	47.38 1203.4	425 193.0
904	21.88 555.8	49.38 1254.3	427 193.9
2374-xx-324	8.88 225.6	40.38 1025.7	308 139.8
330	8.88 225.6	44.38 1127.3	310 140.7
336	8.88 225.6	46.38 1178.1	313 142.1
902	8.88 225.6	34.38 873.3	298 135.3
2375-xx-320	11.12 282.5	40.50 1028.7	327 148.5
324	11.12 282.5	42.50 1079.5	329 149.4
330	11.12 282.5	46.50 1181.1	331 150.3
336	11.12 282.5	48.50 1231.9	334 151.6
902	11.12 282.5	36.50 927.1	319 144.8
903	11.12 282.5	36.50 927.1	321 145.7
904	11.12 282.5	38.50 977.9	322 146.2
2376-xx-316	13.25 336.6	40.62 1031.8	346 157.1
320	13.25 336.6	42.62 1082.6	348 158.0
324	13.25 336.6	44.62 1133.4	349 158.4
330	13.25 336.6	48.62 1235.0	352 159.8
336	13.25 336.6	50.62 1285.8	355 161.2
902	13.25 336.6	38.62 981.0	340 154.4
903	13.25 336.6	38.62 981.0	342 155.3
904	13.25 366.6	40.62 1031.8	343 155.7
2377-xx-310	15.38 390.7	40.88 1038.4	362 164.3
312	15.38 390.7	40.88 1038.4	363 164.8
316	15.38 390.7	42.88 1089.2	365 165.7
320	15.38 390.7	44.88 1140.2	369 167.5
324	15.38 390.7	46.88 1190.8	370 168.0
330	15.38 390.7	50.88 1292.4	373 169.3
336	15.38 390.7	52.88 1343.2	376 170.7
903	15.38 390.7	40.88 1038.4	363 164.8
904	15.38 390.7	42.88 1089.2	364 165.3
2378-xx-308	17.63 447.8	41.00 1041.4	382 173.4
310	17.63 447.8	43.00 1092.2	383 173.9
312	17.63 447.8	43.00 1092.2	385 174.8
316	17.63 447.8	45.00 1143.0	386 175.2
320	17.63 447.8	47.00 1193.8	389 176.6
324	17.63 447.8	49.00 1244.6	391 177.5
330	17.63 447.8	53.00 1346.2	394 178.9
336	17.63 447.8	55.00 1397.0	396 179.8
402	17.63 447.8	41.00 1041.4	381 173.0
404	17.63 447.8	41.00 1041.4	382 173.4
902	17.63 447.8	43.00 1092.2	382 173.4
903	17.63 447.8	43.00 1092.2	383 173.9
904	17.63 447.8	45.00 1143.0	385 174.8
2379-xx-308	19.75 495.7	43.12 1095.3	403 183.0
310	19.75 495.7	45.12 1146.1	404 183.4
312	19.75 495.7	45.12 1146.1	405 183.9
316	19.75 495.7	47.12 1196.9	408 185.2
320	19.75 495.7	49.12 1247.7	410 186.1
324	19.75 495.7	51.12 1298.5	412 187.0
330	19.75 495.7	55.12 1400.1	415 188.4
336	19.75 495.7	57.12 1450.9	418 189.8
402	19.75 495.7	41.12 1044.5	402 182.5
403	19.75 495.7	41.12 1044.5	402 182.5
404	19.75 495.7	41.12 1044.5	403 183.0
902	19.75 495.7	43.12 1095.3	403 183.0
903	19.75 495.7	43.12 1095.3	404 183.5
904	19.75 495.7	45.12 1146.1	406 184.3

Series 2400 Reels

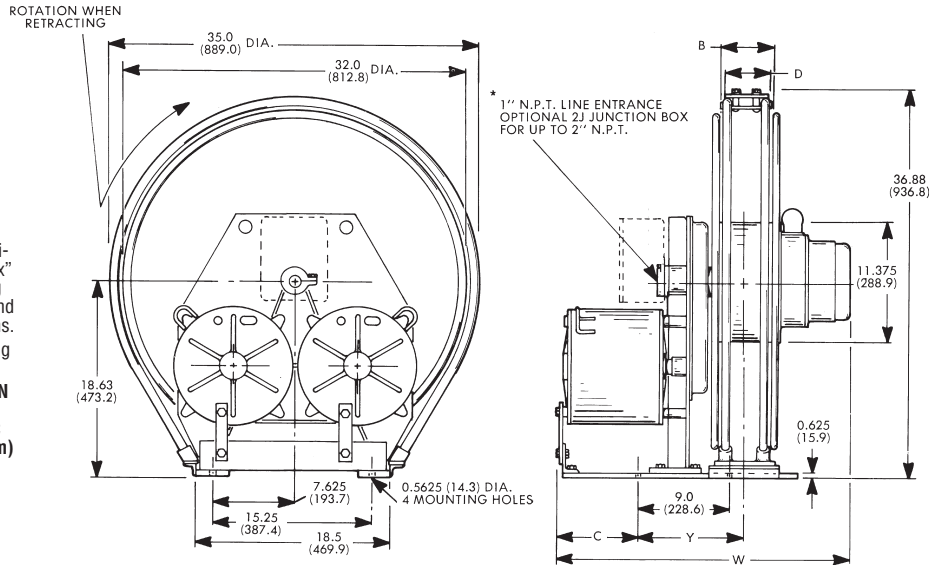

Chart shows dimensional variables within a reel series – “xx” in the catalog number listing represents the drive system and does not affect reel dimensions. See page 35 for slip ring rating and junction box detail.
MILL DUTY SERVICE OPTION
 (Page 28)
 will increase Dimensions C and W by 2.86 inches (73 mm)

Series No.	Dim. B in. mm	Dim. D in. mm	Dim. Y in. mm
2445	4.00 101.6	4.88 124.0	9.25 235.0
2446	4.00 101.6	4.88 124.0	9.25 235.0
2447	4.00 101.6	4.88 124.0	9.25 235.0
2448	4.00 101.6	4.88 124.0	9.25 235.0
2449	4.00 101.6	4.88 124.0	9.25 235.0
2470	7.00 177.8	6.19 157.2	10.75 273.1
2476	7.00 177.8	6.19 157.2	10.75 273.1
2477	7.00 177.8	6.19 157.2	10.75 273.1
2478	7.00 177.8	6.19 157.2	10.75 273.1
2479	7.00 177.8	6.19 157.2	10.75 273.1

Model	Dim. C in. mm	Dim. W in. mm	Weight lbs. Kg
2476-xx-320	13.25 336.6	42.62 1082.6	503 228.4
324	13.25 336.6	44.62 1133.4	505 229.3
330	13.25 336.6	48.62 1235.0	508 230.6
336	13.25 336.6	50.62 1285.8	510 231.5
402	13.25 336.6	36.62 930.2	494 224.3
403	13.25 336.6	36.62 930.2	495 224.7
404	13.25 336.6	36.62 930.2	495 224.7
902	13.25 336.6	38.62 981.0	496 225.2
903	13.25 336.6	38.62 981.0	497 225.6
904	13.25 336.6	38.62 981.0	499 226.5

Model	Dim. C in. mm	Dim. W in. mm	Weight lbs. Kg
2445-xx-403	11.12 282.5	31.50 800.1	448 203.4
404	11.12 282.5	31.50 800.1	449 203.8
2446-xx-303	13.25 336.6	31.62 803.2	488 221.6
306	13.25 336.6	33.62 854.0	490 222.5
308	13.25 336.6	35.63 905.0	491 222.9
402	13.25 336.6	33.62 854.0	489 222.0
403	13.25 336.6	33.62 854.0	490 222.5
404	13.25 336.6	33.62 854.0	490 222.5
903	13.25 336.6	35.62 905.0	491 222.9
2447-xx-304	15.38 390.7	33.88 860.6	530 240.1
306	15.38 390.7	35.88 911.4	530 240.1
402	15.38 390.7	35.88 911.4	532 241.5
403	15.38 390.7	35.88 911.4	532 241.5
404	15.38 390.7	35.88 911.4	532 241.5
2448-xx-308	17.63 447.8	38.00 965.2	574 260.6
402	17.63 447.8	38.00 965.2	574 260.6
403	17.63 447.8	38.00 965.2	574 260.6
404	17.63 447.8	38.00 965.2	574 260.6
2449-xx-402	19.75 495.7	40.12 1019.1	615 279.2
404	19.75 495.7	40.12 1019.1	616 279.7
2470-xx-308	21.88 555.8	45.38 1152.7	663 301.0
402	21.88 555.8	45.38 1152.7	662 300.5
403	21.88 555.8	45.38 1152.7	662 300.5
404	21.88 555.8	45.38 1152.7	663 301.0
903	21.88 555.8	47.38 1203.5	664 301.5
904	21.88 555.8	49.38 1254.3	666 302.4
2476-xx-310	13.25 336.6	36.62 930.2	496 225.2
310	13.25 336.6	38.62 981.0	497 225.6
312	13.25 336.6	38.62 981.0	498 226.1
316	13.25 336.6	40.62 1031.8	500 227.0

Model	Dim. C in. mm	Dim. W in. mm	Weight lbs. Kg
2477-xx-306	15.38 390.7	38.88 987.6	537 243.8
308	15.38 390.7	38.88 987.6	538 244.3
310	15.38 390.7	40.88 1038.4	539 244.7
312	15.38 390.7	40.88 1038.4	540 245.2
316	15.38 390.7	42.88 1089.2	541 245.6
320	15.38 390.7	44.88 1140.0	545 247.4
324	15.38 390.7	46.88 1190.8	547 248.3
330	15.38 390.7	50.88 1292.4	550 249.7
336	15.38 390.7	52.88 1343.2	555 252.0
402	15.38 390.7	38.88 987.6	536 243.3
403	15.38 390.7	38.88 987.6	537 243.8
404	15.38 390.7	38.88 987.6	537 243.8
902	15.38 390.7	40.88 1038.4	537 243.8
903	15.38 390.7	40.88 1038.4	539 244.7
904	15.38 390.7	40.88 1038.4	540 245.2
2478-xx-306	17.63 447.8	41.00 1041.4	578 262.4
308	17.63 447.8	41.00 1041.4	580 263.3
310	17.63 447.8	43.00 1092.2	580 263.3
312	17.63 447.8	43.00 1092.2	581 263.8
316	17.63 447.8	45.00 1143.0	583 264.7
320	17.63 447.8	47.00 1193.8	586 266.0
324	17.63 447.8	49.00 1244.6	589 267.4
330	17.63 447.8	53.00 1346.2	591 268.3
336	17.63 447.8	55.00 1397.0	594 269.7
402	17.63 447.8	41.00 1041.4	578 262.4
403	17.63 447.8	41.00 1041.4	579 262.9
404	17.63 447.8	41.00 1041.4	579 262.9
902	17.63 447.8	43.00 1092.2	579 262.9
903	17.63 447.8	43.00 1092.2	581 263.8
904	17.63 447.8	45.00 1143.0	582 264.2
2479-xx-308	19.75 495.7	43.12 1095.3	621 281.9
310	19.75 495.7	45.12 1146.1	622 282.4
312	19.75 495.7	45.12 1146.1	623 282.8
330	19.75 495.7	55.12 1400.1	623 282.8
402	19.75 495.7	43.12 1095.3	620 281.5
404	19.75 495.7	43.12 1095.3	621 281.9
902	19.75 495.7	45.12 1146.1	621 281.9
904	19.75 495.7	47.12 1196.9	624 283.3

Dimensions

Series 2500&2600 Reels

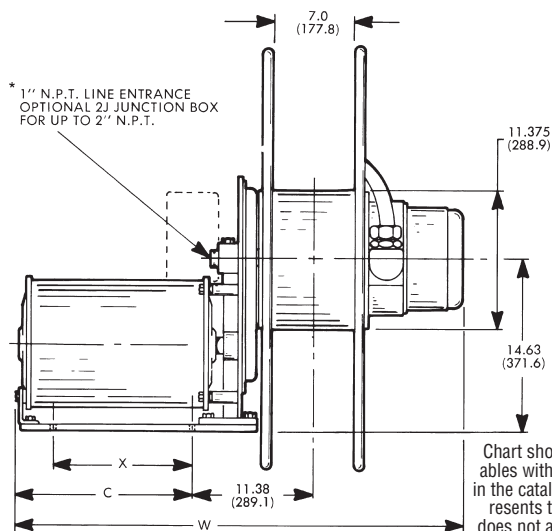
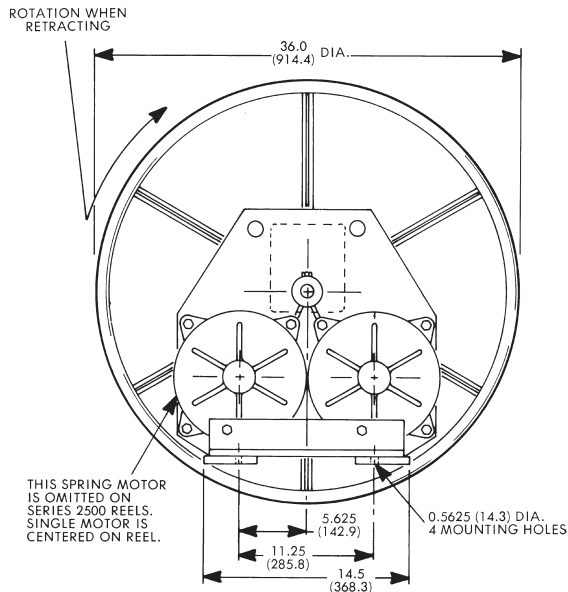

Chart shows dimensional variables within a reel series – “xx” in the catalog number listing represents the drive system and does not affect reel dimensions. See page 35 for slip ring rating and junction box detail.

MILL DUTY SERVICE OPTION (Page 28) will increase Dims. C and W by 2.86 inches (73 mm)

Model	Dim. X in. mm	Dim. C in. mm	Dim. W in. mm	Weight lbs. Kg
2570-xx-324	16.94 430.3	21.96 557.8	54.88 1394.0	429 194.8
404	16.94 430.3	21.96 557.8	46.88 1191.0	422 191.6
902	16.94 430.3	21.96 557.8	48.88 1241.6	419 190.2
903	16.94 430.3	21.96 557.8	48.88 1241.6	420 190.7
904	16.94 430.3	21.96 557.8	50.88 1292.4	422 191.6
2576-xx-308	8.25 209.6	13.27 337.1	38.13 968.5	336 152.5
310	8.25 209.6	13.27 337.1	40.13 1019.3	337 153.0
312	8.25 209.6	13.27 337.1	40.13 1019.3	338 153.5
316	8.25 209.6	13.27 337.1	42.13 1070.1	340 154.4
320	8.25 209.6	13.27 337.1	44.13 1120.9	343 155.7
324	8.25 209.6	13.27 337.1	46.13 1171.7	345 156.7
330	8.25 209.6	13.27 337.1	50.13 1273.3	348 158.0
336	8.25 209.6	13.27 337.1	52.13 1324.1	350 158.9
402	8.25 209.6	13.27 337.1	38.13 968.5	334 151.6
403	8.25 209.6	13.27 337.1	38.13 968.5	335 152.1
902	8.25 209.6	13.27 337.1	40.13 1019.3	336 152.5
2577-xx-308	10.44 265.2	15.62 396.8	40.50 1028.7	357 162.1
310	10.44 265.2	15.62 396.8	42.50 1079.5	358 162.5
312	10.44 265.2	15.62 396.8	42.50 1079.5	359 163.0
316	10.44 265.2	15.62 396.8	44.50 1130.3	360 163.4
320	10.44 265.2	15.62 396.8	46.50 1181.1	364 165.3
324	10.44 265.2	15.62 396.8	48.50 1231.9	366 166.2
330	10.44 265.2	15.62 396.8	52.50 1333.5	396 167.5
336	10.44 265.2	15.62 396.8	54.50 1384.3	371 168.4
402	10.44 265.2	15.62 396.8	40.50 1028.7	355 161.2
403	10.44 265.2	15.62 396.8	40.50 1028.7	356 161.6
404	10.44 265.2	15.62 396.8	40.50 1028.7	356 161.6
902	10.44 265.2	15.62 396.8	42.50 1079.5	357 162.1
2578-xx-306	12.56 319.0	17.62 447.5	42.50 1079.5	377 171.2
310	12.56 319.0	17.62 447.5	44.50 1130.3	379 172.1
312	12.56 319.0	17.62 447.5	44.50 1130.3	380 172.5
320	12.56 319.0	17.62 447.5	48.50 1231.9	385 174.8
324	12.56 319.0	17.62 447.5	50.50 1282.7	387 175.7
330	12.56 319.0	17.62 447.5	54.50 1384.3	389 176.6
336	12.56 319.0	17.62 447.5	56.50 1435.1	392 178.0
403	12.56 319.0	17.62 447.5	42.50 1079.5	377 171.2
404	12.56 319.0	17.62 447.5	42.50 1079.5	377 171.2
902	12.56 319.0	17.62 447.5	44.50 1130.3	377 171.2
903	12.56 319.0	17.62 447.5	44.50 1130.3	379 172.1
904	12.56 319.0	17.62 447.5	46.50 1181.1	380 172.5

Model	Dim. X in. mm	Dim. C in. mm	Dim. W in. mm	Weight lbs. Kg
2579-xx-404	14.75 374.7	19.79 502.7	44.63 1133.6	398 180.7
903	14.75 374.7	19.79 502.7	46.63 1184.4	400 181.6
904	14.75 374.7	19.79 502.7	48.63 1235.2	401 182.1
2670-xx-310	16.94 430.3	21.96 557.8	48.88 1241.6	660 299.6
312	16.94 430.3	21.96 557.8	48.88 1241.6	660 299.6
316	16.94 430.3	21.96 557.8	50.88 1292.4	662 300.5
320	16.94 430.3	21.96 557.8	52.88 1343.2	666 302.4
324	16.94 430.3	21.96 557.8	54.88 1394.0	668 303.2
336	16.94 430.3	21.96 557.8	60.88 1546.4	673 305.5
403	16.94 430.3	21.96 557.8	46.88 1190.8	658 298.7
404	16.94 430.3	21.96 557.8	46.88 1190.8	658 298.7
902	16.94 430.3	21.96 557.8	48.88 1241.6	658 298.7
903	16.94 430.3	21.96 557.8	48.88 1241.6	660 299.6
904	16.94 430.3	21.96 557.8	50.88 1292.4	661 300.1
2676-xx-320	8.25 209.6	13.27 337.1	44.13 1120.9	499 226.5
324	8.25 209.6	13.27 337.1	46.13 1171.7	500 227.0
330	8.25 209.6	13.27 337.1	50.13 1273.3	503 228.4
336	8.25 209.6	13.27 337.1	52.13 1324.1	506 229.7
902	8.25 209.6	13.27 337.1	40.13 1019.3	491 222.9
2677-xx-320	10.44 265.2	15.62 396.8	46.50 1181.1	540 245.2
324	10.44 265.2	15.62 396.8	48.50 1231.9	542 246.1
330	10.44 265.2	15.62 396.8	52.50 1333.5	545 247.3
336	10.44 265.2	15.62 396.8	54.50 1384.3	548 248.8
902	10.44 265.2	15.62 396.8	42.50 1079.5	533 242.0
903	10.44 265.2	15.62 396.8	42.50 1079.5	534 242.4
904	10.44 265.2	15.62 396.8	44.50 1130.3	536 243.3
2678-xx-316	12.56 319.0	17.62 447.5	46.50 1181.1	579 262.9
320	12.56 319.0	17.62 447.5	48.50 1231.9	584 265.1
330	12.56 319.0	17.62 447.5	54.50 1384.3	587 266.5
903	12.56 319.0	17.62 447.5	44.50 1130.3	576 261.5
904	12.56 319.0	17.62 447.5	46.50 1181.1	578 262.4
2679-xx-310	14.75 374.7	19.79 502.7	46.63 1184.4	618 280.6
316	14.75 374.7	19.79 502.7	48.63 1235.2	620 281.5
320	14.75 374.7	19.79 502.7	50.63 1286.0	624 283.3
324	14.75 374.7	19.79 502.7	52.63 1336.8	626 284.2
336	14.75 374.7	19.79 502.7	58.63 1489.2	631 286.5
403	14.75 374.7	19.79 502.7	44.63 1133.6	616 279.7
404	14.75 374.7	19.79 502.7	44.63 1133.6	616 279.7
902	14.75 374.7	19.79 502.7	46.63 1184.4	617 280.1
903	14.75 374.7	19.79 502.7	46.63 1184.4	618 280.6
904	14.75 374.7	19.79 502.7	48.63 1235.2	620 281.5

Series 2700&2800 Reels

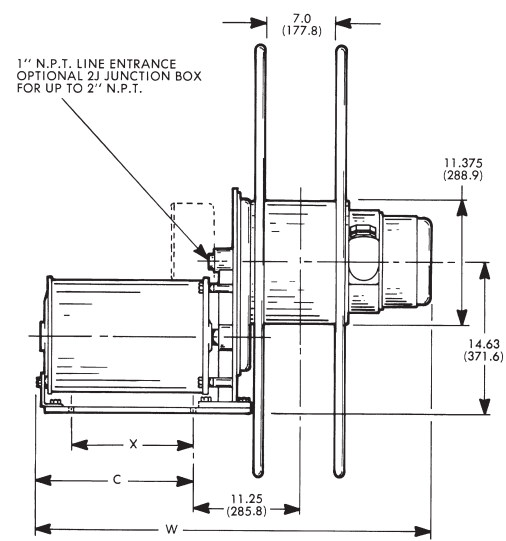
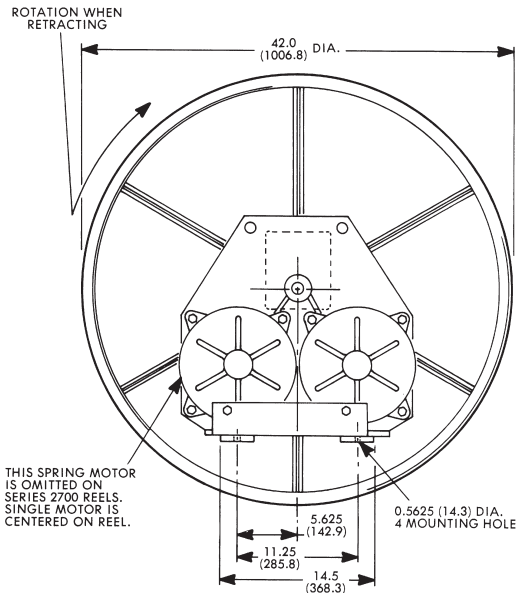

Chart shows dimensional variables within a reel series - "xx" in the catalog number listing represents the drive system and does not affect reel dimensions. See page 35 for slip ring rating and junction box detail.

MILL DUTY SERVICE OPTION (Page 28) will increase Dimensions C and W by 2.86 inches (73 mm)

Model	Dim. X in. mm	Dim. C in. mm	Dim. W in. mm	Weight lbs. Kg
2770-xx-312	16.94 430.3	21.96 557.8	48.88 1241.6	448 203.4
316	16.94 430.3	21.96 557.8	50.88 1292.4	450 204.3
320	16.94 430.3	21.96 557.8	52.88 1343.2	454 206.1
324	16.94 430.3	21.96 557.8	54.88 1394.0	456 207.0
330	16.94 430.3	21.96 557.8	58.88 1495.6	458 207.9
336	16.94 430.3	21.96 557.8	60.88 1546.4	461 209.3
402	16.94 430.3	21.96 557.8	46.88 1190.8	445 202.0
404	16.94 430.3	21.96 557.8	46.88 1190.8	446 202.5
902	16.94 430.3	21.96 557.8	48.88 1241.6	448 203.4

2777-xx-310	10.44 265.2	15.62 396.8	42.50 1079.5	385 174.8
324	10.44 265.2	15.62 396.8	48.50 1231.9	393 178.4
2778-xx-308	12.56 319.0	17.62 447.5	42.50 1079.5	405 183.9
310	12.56 319.0	17.62 447.5	44.50 1130.3	406 184.3
312	12.56 319.0	17.62 447.5	44.50 1130.3	407 184.8
316	12.56 319.0	17.62 447.5	46.50 1181.1	408 185.2
320	12.56 319.0	17.62 447.5	48.50 1231.9	412 187.0
324	12.56 319.0	17.62 447.5	50.50 1282.7	414 188.0
330	12.56 319.0	17.62 447.5	54.50 1384.3	416 188.9

2779-xx-308	14.75 374.7	19.79 502.7	44.63 1133.6	426 193.4
310	14.75 374.7	19.79 502.7	46.63 1184.4	427 193.9
312	14.75 374.7	19.79 502.7	46.63 1184.4	427 193.9
316	14.75 374.7	19.79 502.7	48.63 1235.2	429 194.8
320	14.75 374.7	19.79 502.7	50.63 1286.0	433 196.6
324	14.75 374.7	19.79 502.7	52.63 1336.8	435 197.5
336	14.75 374.7	19.79 502.7	58.63 1489.2	440 199.8

2870-xx-316	16.94 430.3	21.96 557.8	50.88 1292.4	689 312.8
320	16.94 430.3	21.96 557.8	52.88 1343.2	693 314.6
324	16.94 430.3	21.96 557.8	54.88 1394.0	695 315.5
330	16.94 430.3	21.96 557.8	58.88 1495.6	697 316.4
336	16.94 430.3	21.96 557.8	60.88 1546.4	700 317.8
902	16.94 430.3	21.96 557.8	48.88 1241.6	685 311.0
903	16.94 430.3	21.96 557.8	48.88 1241.6	687 311.9
904	16.94 430.3	21.96 557.8	50.88 1292.4	688 312.4

2875-xx-324	6.06 153.9	11.10 281.9	44.00 1117.6	486 220.6
330	6.06 153.9	11.10 281.9	48.00 1219.2	488 221.6
404	6.06 153.9	11.10 281.9	36.00 914.4	476 216.1
902	6.06 153.9	11.10 281.9	38.00 965.2	476 216.1

Model	Dim. X in. mm	Dim. C in. mm	Dim. W in. mm	Weight lbs. Kg
2876-xx-316	8.25 209.6	13.27 337.6	42.13 1070.1	522 237.0
320	8.25 209.6	13.27 337.6	44.13 1120.9	526 238.8
324	8.25 209.6	13.27 337.6	46.13 1171.7	527 239.3
330	8.25 209.6	13.27 337.6	50.13 1273.3	530 240.6
403	8.25 209.6	13.27 337.6	38.13 968.5	517 234.7
404	8.25 209.6	13.27 337.6	38.13 968.5	518 235.2
902	8.25 209.6	13.27 337.6	40.13 1019.3	518 235.2
903	8.25 209.6	13.27 337.6	40.13 1019.3	520 236.1
904	8.25 209.6	13.27 337.6	42.13 1070.1	521 236.5

2877-xx-312	10.44 265.2	15.62 396.8	42.50 1079.5	562 255.1
316	10.44 265.2	15.62 396.8	44.50 1130.3	564 256.1
324	10.44 265.2	15.62 396.8	48.50 1231.9	568 257.9
330	10.44 265.2	15.62 396.8	52.50 1333.5	572 259.7
336	10.44 265.2	15.62 396.8	54.50 1384.3	575 261.1
402	10.44 265.2	15.62 396.8	40.50 1028.7	559 253.8
403	10.44 265.2	15.62 396.8	40.50 1028.7	559 253.8
404	10.44 265.2	15.62 396.8	40.50 1028.7	560 254.2
902	10.44 265.2	15.62 396.8	42.50 1079.5	560 254.2
903	10.44 265.2	15.62 396.8	42.50 1079.5	561 254.7
904	10.44 265.2	15.62 396.8	44.50 1130.3	563 255.6

2878-xx-320	12.56 319.0	17.62 447.5	48.50 1231.9	609 276.5
324	12.56 319.0	17.62 447.5	50.50 1282.7	611 277.4
330	12.56 319.0	17.62 447.5	54.50 1384.3	612 277.8
336	12.56 319.0	17.62 447.5	56.50 1435.1	616 279.7
902	12.56 319.0	17.62 447.5	44.50 1130.3	602 273.3
904	12.56 319.0	17.62 447.5	46.50 1181.1	605 274.7

2879-xx-320	14.75 374.7	19.79 502.7	50.63 1286.0	651 295.6
324	14.75 374.7	19.79 502.7	52.63 1336.8	653 296.5
330	14.75 374.7	19.79 502.7	56.63 1438.4	656 297.8
902	14.75 374.7	19.79 502.7	46.63 1184.4	644 292.4
903	14.75 374.7	19.79 502.7	46.63 1184.4	646 293.3
904	14.75 374.7	19.79 502.7	48.63 1235.2	648 294.2

AERO-MOTIVE®

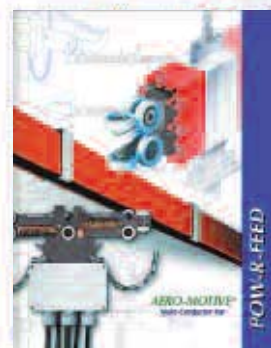
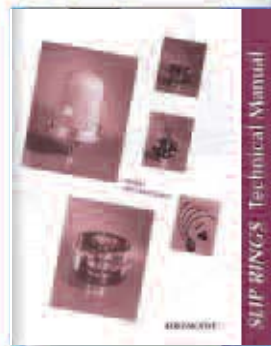
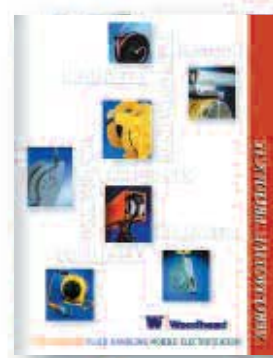

W | Woodhead

United States/Mexico
Woodhead L.P.
3411 Woodhead Drive
Northbrook, IL 60062
1-800-999-8559
FAX: 1-800-333-6119
woodhead.com

Canada
Woodhead Canada Limited
1090 Brevik Place
Mississauga, Ontario L4W 3Y5
1-905-624-6518
FAX: 1-905-624-9151
www.woodhead.ca

Europe
Woodhead Connectivity Ltd.
Factory No. 9
Rassau Industrial Estate
Ebbw Vale, Gwent, Wales
United Kingdom NP23 5SD
011-44-1495-350436
FAX: 011-44-1495-350877
sales@wdhd.co.uk

Asia
Woodhead Asia Pte. Ltd.
No. 4 Toh Tuck Link
Level 3, Mezzanine
Markono Logistics Bldg.
Singapore 596 226
+(65)-6261-6533
FAX: 65-62-261-3588
sales.asia@woodhead.com

Japan
Woodhead Japan Corp.
3G Kawashima No. 5 Bldg.
29-16 Imaike-Minami
Chikusa-ku
Nagoya 464-0851 Japan
011-81-52-745-7621